

MECHANICAL REBAR SPLICING SYSTEMS

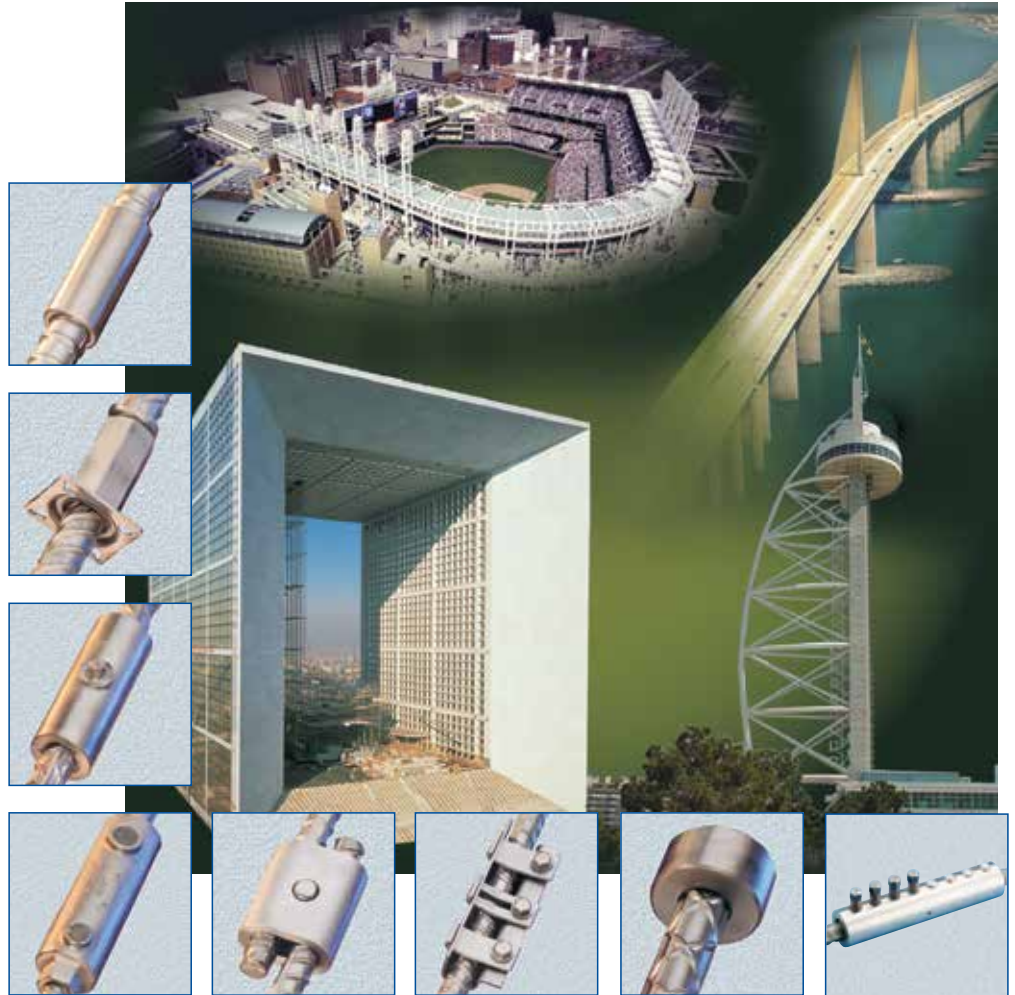

Introduction

LENTON is a world-leading brand of advanced mechanical rebar splicing systems. The “Rebar Splicing Specialists” at Pentair understand the concrete construction business and inherent rebar splicing problems. Our engineering capabilities, broad experience and extensive testing base combined with our multiple splicing and anchorage systems, allow us to provide engineers and contractors with product solutions to rebar splicing challenges – today and into the future.

Ease of use, reliability, structural integrity, and minimal congestion are the benefits of using Pentair products. Our systems will handle your needs in tension, compression, cyclic and stress reversal applications.

LENTON mechanical rebar splices are tested and proven. They offer the most effective method of joining reinforcing bars and meet the codes of national and international regulatory organizations.

Our products are:

- LENTON Taper Threaded Splices
- LENTON FORM SAVER
- LENTON INTERLOK
- LENTON SPEED SLEEVE
- LENTON QUICK WEDGE
- LENTON TERMINATOR
- CADWELD Rebar Splices
- LENTON LOCK

Lap splices depend on concrete for strength, and therefore lack structural integrity and continuity in concrete construction.

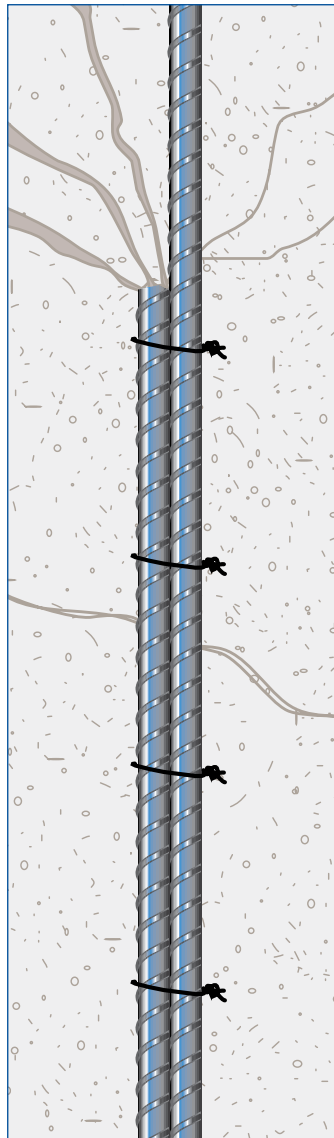

Mechanical splicing provides the assurance of maintaining load path continuity of the structural reinforcement, independent of the condition or existence of the concrete.

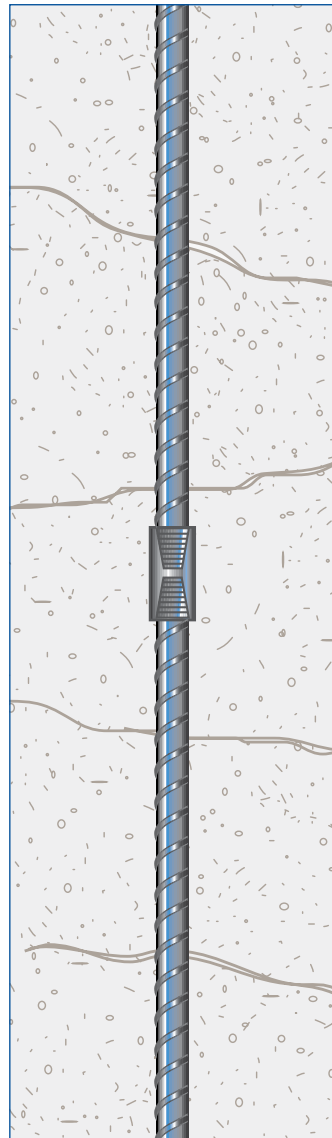

Benefits of Mechanical Splicing

More and more engineers are specifying mechanical rebar connections over lap splices. They've found that mechanical connections afford a reliability and consistency that can't be found with lap splicing.

- Mechanical systems are more reliable than lap systems because they don't depend on the concrete for load transfer.
- Mechanical connections offer greater structural integrity. Mechanical splices offer strength and toughness during man-made, seismic or other natural events.
- Codes require that mechanical splices deliver higher performance than typical design lengths for lap splices. This is typically 125% to 150% greater capacity* provided by the mechanical splice versus the lap splice.
- Lap splicing increases rebar congestion at the lap zone and is one of the major causes for forming rock pockets and voids in the concrete. Mechanical splices eliminate these congestion problems and will make the overall job more cost effective through minimized job site problems.
- Building codes stipulate a steel ratio of under 8% and this makes it nearly impossible to achieve a balanced design with lap splicing. Mechanical splices allow the designer to achieve an ideal balance of steel and concrete by eliminating the additional rebar in the lap zone.

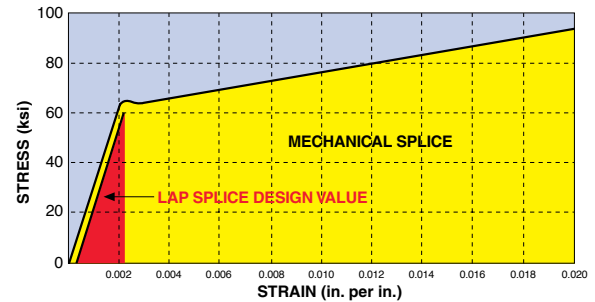

- Working with "small" diameter reinforcing bars may require the use of larger column dimensions to accommodate a greater quantity of bars. Using mechanical splices allows the option of larger diameter rebar in a smaller column while minimizing congestion. This reduced column size results in a more efficient design and an *optimum use of floor space*.
- Mechanical splices eliminate tedious lap calculations.
- Mechanical splices are fast and easy to install and require no specialized skilled labor.
- Mechanical splices are cost effective by reducing labor costs and accelerating job schedules.
- Dowel bar substitutes reduce labor on site, form-work costs and increase job site safety.
- Bar terminators eliminate congestion and simplify bar placing.
- Repair splices eliminate the cost of breaking away massive amounts of concrete.

* Depending on reinforcing bar standard

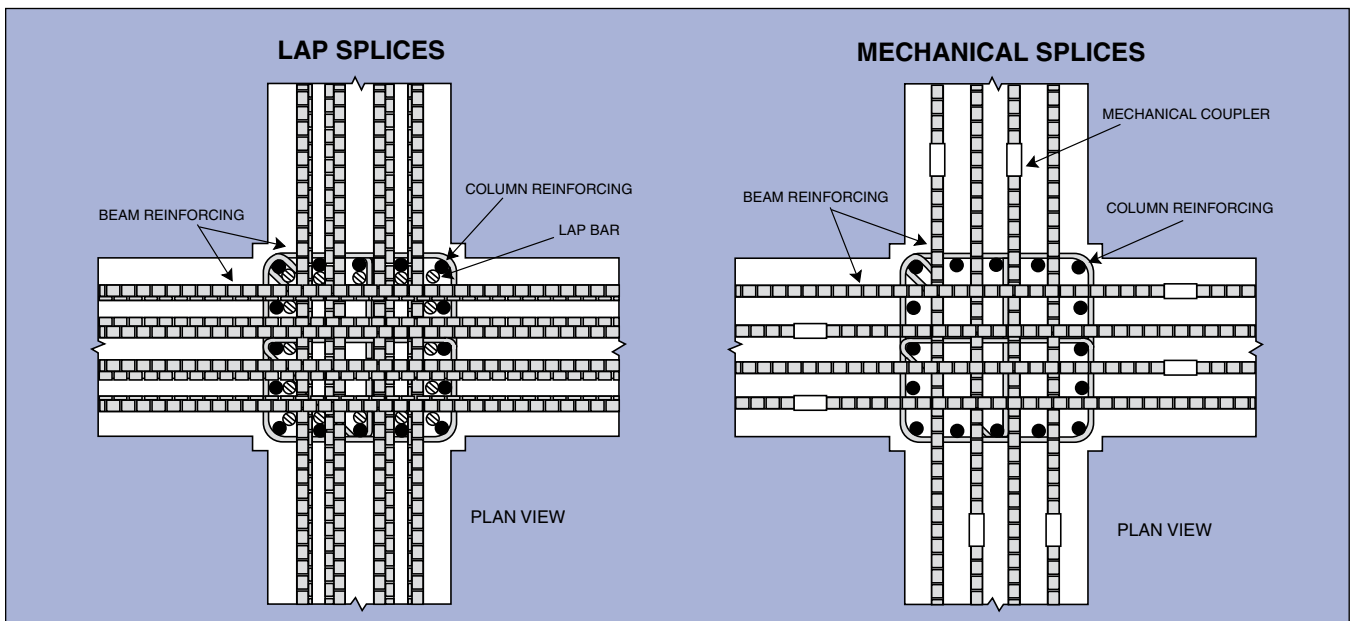









The LENTON Rebar Splicing Family

LENTON

International Codes & Standards

LENTON mechanical splices meet the requirements of major international codes and standards:

-  Australia
AS3600
-  Austria
ÖNORM B 4700
-  Brazil
ABNT – NBR 8548 – AGO/84
-  Canada
CAN/CSA - N287.2
CAN/CSA - N287.3
CAN/CSA - N287.4
-  Chile
NCH 204
-  China
GB 1499-91
-  Finland
BY 4B
-  France
NF A 35-020-1
-  Germany
DIN EN1992-1-1
-  Japan
JIS G3112
-  Malaysia
MS146
-  Netherlands
NEN EN1992-1-1
-  United Kingdom
BS EN1992-1-1
Sellafeld Ltd.
-  United States
AASHTO®; ACI® 318; ACI 349;
ACI 359 / ASME®-III div 2,
ASME QSC, IAPMO®-UES,
ICC, NQA-1, NRC; U.S. Army
Corps of Engineers



LENTON TAPER THREADED SPLICES

LENTON splices are the slimmest couplers available and their tapered thread makes them the most reliable, easy to install and cost effective system. The LENTON taper threaded range consists of standard and transition couplers as well as positional couplers to join bars of any shape, size and diameter. Also weldable and bolt couplers are available for joining structural steel to reinforced concrete.

LENTON FORM SAVER

LENTON FORM SAVER is ideal for eliminating protruding dowel bars in segmental pour applications and temporary openings. It is uniquely designed with the LENTON tapered thread, factory installed thread protector and nailing plate for easy attachment to the form.

CADWELD

CADWELD rebar splices are used where strength and toughness are critical. CADWELD – the world's premier mechanical splicing system – offers consistency as well as versatility and flexibility. CADWELD rebar splicing system is the most used system in nuclear construction worldwide.

CADWELD is also used for no bar end preparation applications where new reinforcement is connected to existing reinforcement.

Pentair manufactures a complete line of rebar splicing systems. Each system is designed to meet different splicing requirements. Pentair has the staff, experience and resources to help select the system that's right for any application. The following is a list of the most popular splicing systems available from Pentair – the rebar splicing specialists.



LENTON INTERLOK

LENTON INTERLOK is a precast joining system, designed to provide structural integrity for joining rebar in precast construction. The LENTON INTERLOK system allows maximum efficiency in precast construction as blockouts and concrete patching are eliminated providing architecturally appealing results.

LENTON QUICK WEDGE

LENTON QUICK WEDGE is designed for retrofit applications and is fast and easy to install. Because it utilizes short dowels, LENTON QUICK WEDGE reduces costly and potentially damaging concrete removal. It is an extremely cost effective system to use for bridge widening, seismic upgrades, closure pours and pile extensions.

LENTON SPEED SLEEVE

LENTON SPEED SLEEVE is the first choice of contractors for compression only applications. LENTON SPEED SLEEVE is uniquely designed for fast, one-man installation and easy inspection. Using square saw cut ends, LENTON SPEED SLEEVE meets international code requirements for compression only splicing.

LENTON TERMINATOR

LENTON TERMINATOR is a taper-threaded anchorage, which is secured to the end of a length of reinforcing steel bar and is capable of creating a more effective anchorage than the traditional hooked rebar. This approach greatly simplifies rebar placement, reduces congestion and improves structural integrity.

LENTON LOCK

LENTON LOCK couplers allow for easy and simple field installation since no bar-end preparation, sawing or swaging is necessary. The couplers can be installed with just a standard wrench or an impact wrench depending on coupler size. The bolt heads will shear off when proper installation tightness has been reached, which allows for visual inspection.

MECHANICAL SPLICING AND ANCHORING

LENTON Taper Threaded Splices • LENTON SPEED SLEEVE • CADWELD
LENTON INTERLOK • LENTON TERMINATOR • LENTON LOCK

LENTON is the most widely used mechanical splicing system in the world today. The LENTON system is designed to connect two pieces of rebar together in the field quickly and easily.

LENTON taper threaded splices utilize the time-tested, field proven taper thread for assurance of strength, consistency and reliability while simplifying installation. Designed for use with worldwide grades of rebar, LENTON develops the full tension splice strength requirement per numerous international design standards. The LENTON system is available in several styles to meet virtually any application. The applications include standard bar-to-bar connections, precaging applications, hooked bar applications, closure pours, precast connections, rebar terminations and anchorages, transition splices, segmental construction and connections to structural steel.

For compression only connections the LENTON SPEED SLEEVE is ideal. LENTON SPEED SLEEVE installs quickly in an easy one man operation.

The CADWELD rebar splicing system is the most widely used mechanical splice in nuclear construction. The CADWELD metal filled splice is also ideal for repair applications.

The LENTON INTERLOK precast joining system is designed to provide structural integrity for joining rebar in precast construction. The system allows maximum efficiency in precast construction as blockouts and concrete patching are eliminated — providing architecturally appealing results.

LENTON TERMINATOR is a replacement for hooked rebar in beam/column, roof/column, piles and pile cap, footings, and just about anywhere a typical hooked bar would be utilized for anchorage in traditional cast-in-place precast construction. The LENTON TERMINATOR is simply an oversized coupling secured to the end of a length of rebar, creating anchorage within the concrete. Pioneered by Pentair in the 1970s, mechanical rebar anchors effectively eliminate the rebar hook, minimize embedment lengths, simplify concrete placement, reduce construction costs and allow greater flexibility in design and construction. In addition to providing an alternative to hooked rebar, it can also be utilized as a stop nut for bar passing through a pile plank or structural steel element.

LENTON LOCK, an in-situ rebar splice from Pentair, requires no bar-end preparation. It is ideal for new construction, repair or retrofit applications. The LENTON LOCK coupler features patented gripping technology that provides for the development of full rebar strength and improved overall structural integrity in tension, compression, stress-reversal and dynamic applications. This innovative mechanical rebar splice is designed for use in column splicing, bridge applications, piling, splicing to protruding dowels cast in concrete, closure pours, beams, chimney construction and other demanding splicing applications.

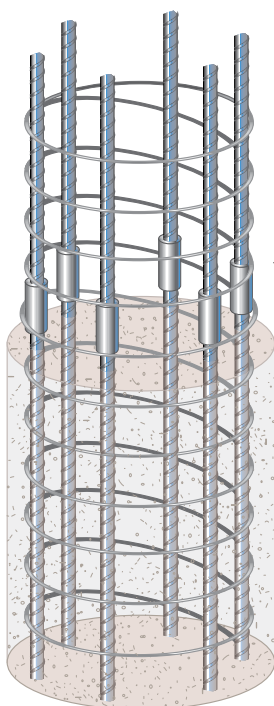

LENTON "A2/A12"
Bar-to-bar connection, where at least one bar is free to rotate. Full tension capacity.

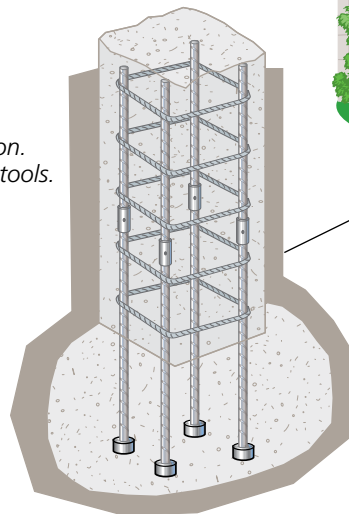

LENTON LOCK
Bar-to-bar connection. Requires no special tools.

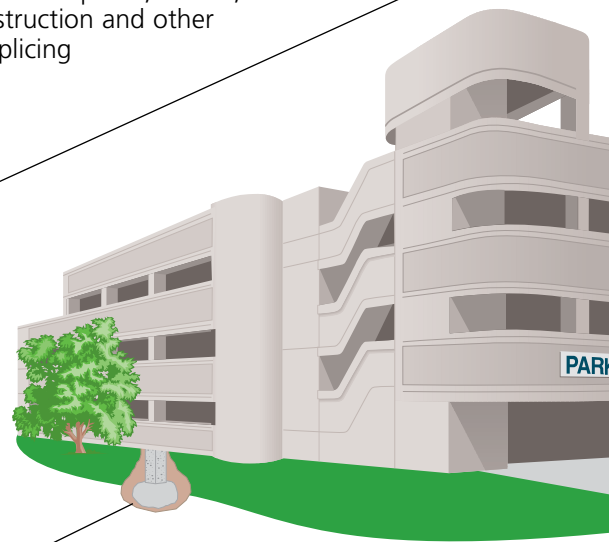

LENTON TERMINATOR
Replacement for bent bars in foundations, pile caps and column footers.

BENT BAR APPLICATIONS

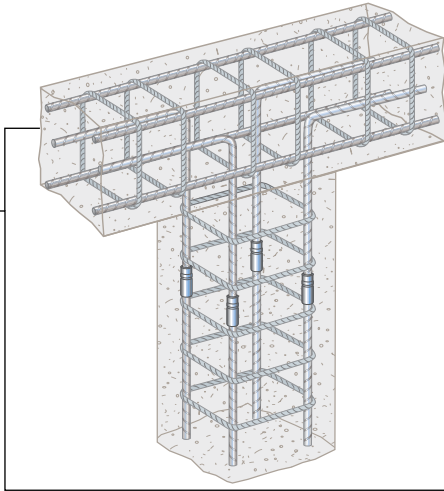

LENTON POSITION COUPLER / LENTON LOCK

For bar-to-bar connections where neither bar can be rotated and where one bar is free to move in its axial direction.

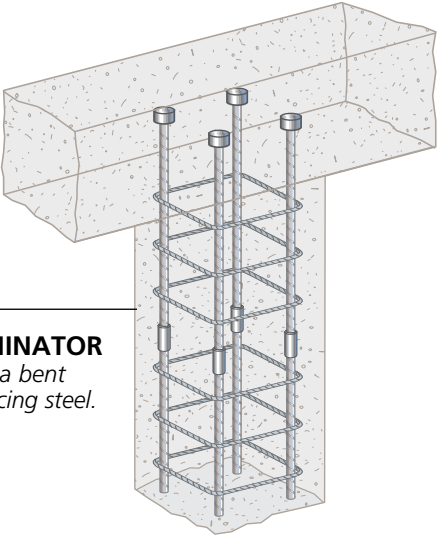

LENTON TERMINATOR

Replacement for a bent section of reinforcing steel.

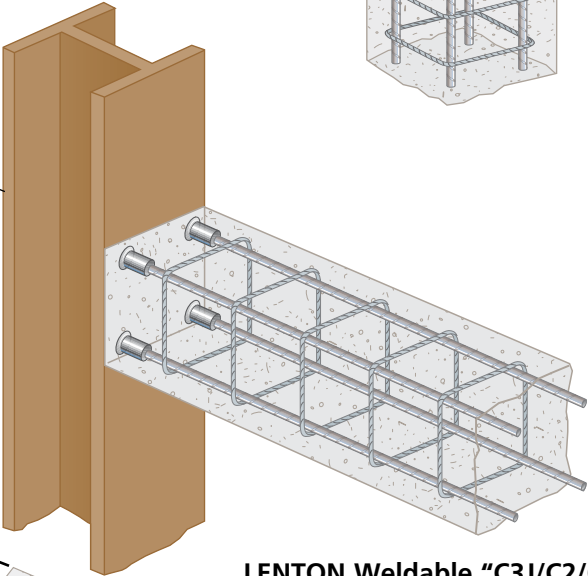

LENTON Weldable "C3J/C2/C12"

Coupler designed to be arc-welded to structural plates and shapes.

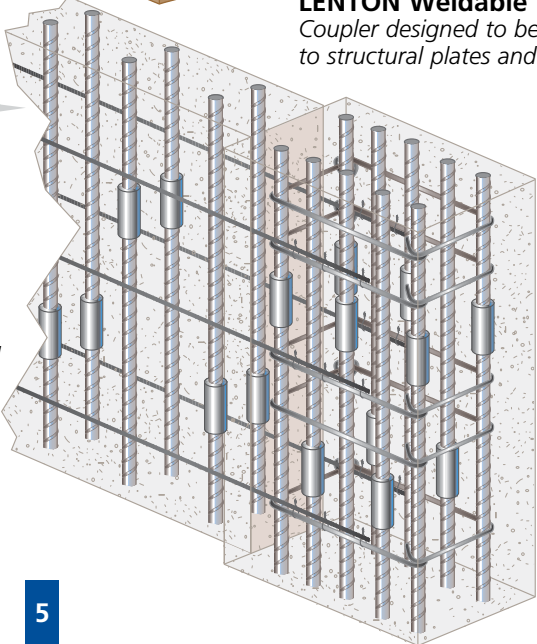

LENTON COUPLERS / LENTON LOCK

Ideal for shear wall applications. Mechanical splices reduce overall congestion.

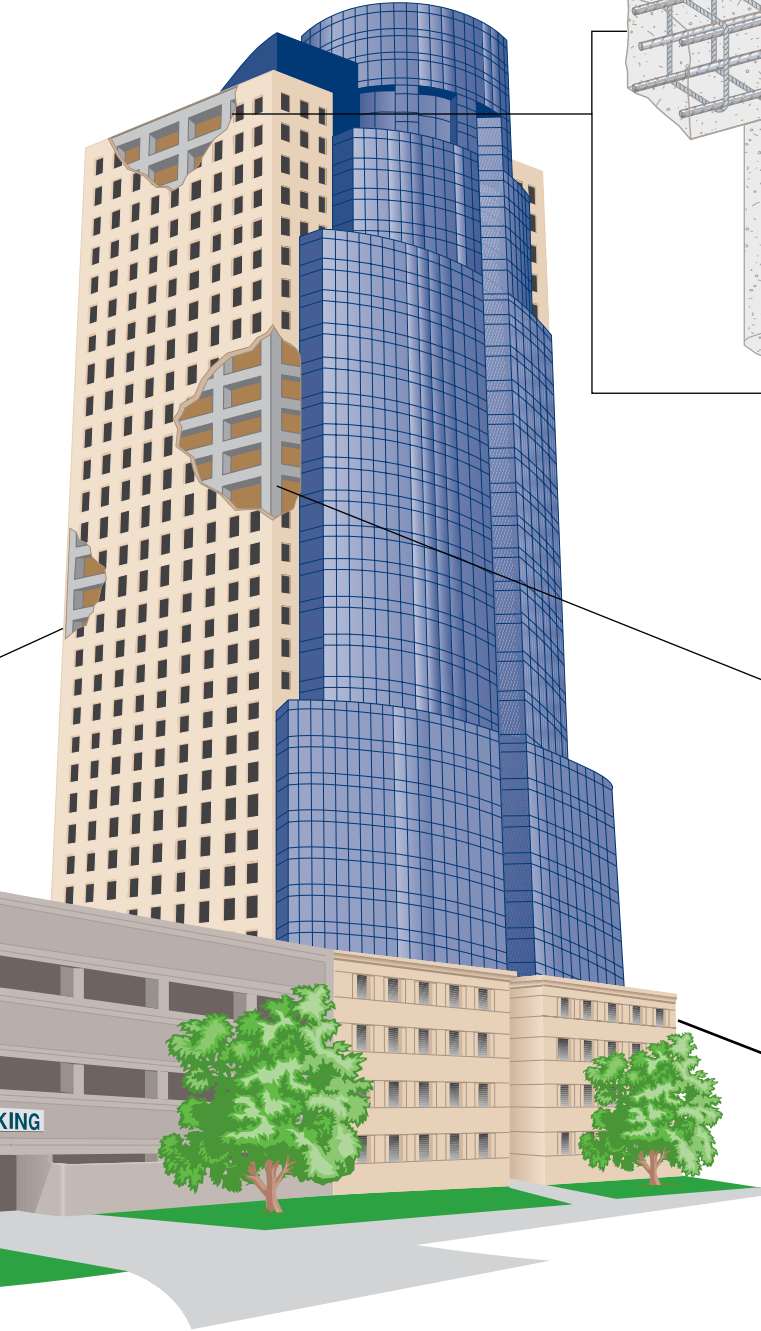

DOWEL BAR REPLACEMENT LENTON FORM SAVER

LENTON FORM SAVER is ideal for segmental pours by eliminating protruding dowels. It is uniquely designed with our LENTON taper thread, factory installed thread protector and keyed mounting holes for easy attachment to the form. LENTON FORM SAVER eliminates drilling expensive formwork and the need for bend/rebend

of rebar. LENTON FORM SAVER is ideal for slip form, jump form, segmental pour, stairwell applications, bridge and highway construction and precast applications. LENTON FORM SAVER is available in sizes #4 through #11 (12 mm – 36 mm).

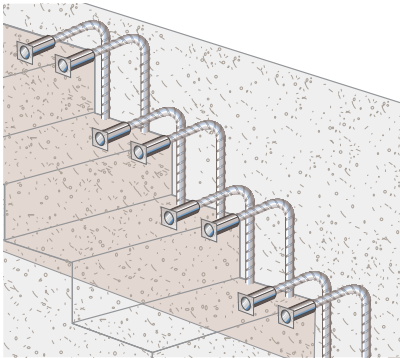

Stairwell

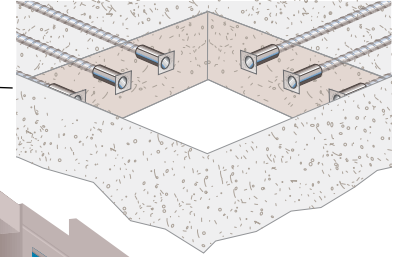

Equipment and
Crane Openings

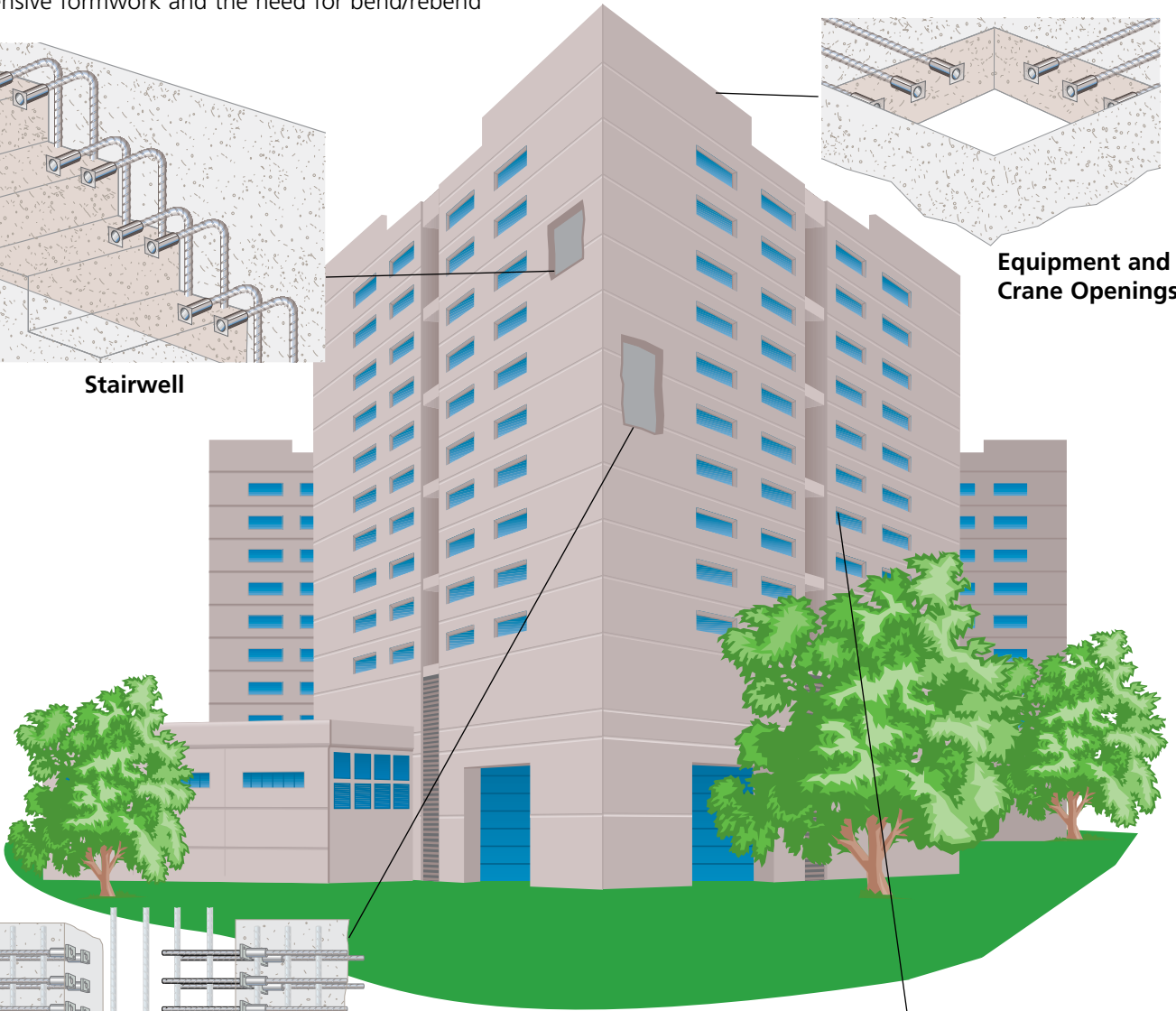

LENTON FORM SAVER

Installed into the precast wall panels. Once the panel is positioned at the jobsite, the matching external threaded rebar is screwed into the coupler to maintain continuity between the cast-in-place and precast sections.

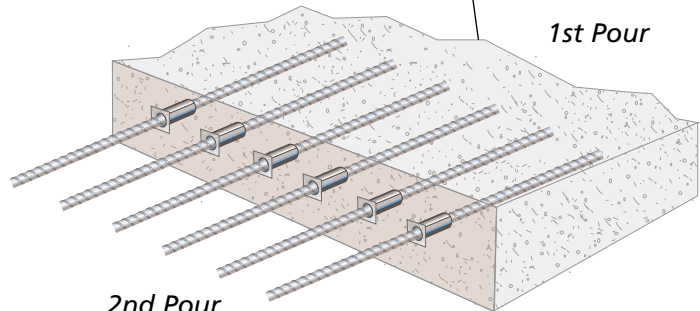

2nd Pour

Floor Slab,
Highway or Bridge Slabs

REPAIR/RETROFIT APPLICATIONS

LENTON QUICK WEDGE • CADWELD Rebar Splicing System • LENTON LOCK

Pentair offers a wide range of products to splice rebar in the field or to repair or extend column or beam bars that are in a structure. Sometimes rebar may be accidentally cut in the field or a structure may get an addition and the reinforcement must be extended. For these applications, Pentair offers several products including the CADWELD rebar splicing system, the LENTON QUICK WEDGE mechanical rebar splice, and LENTON LOCK. The CADWELD splice is the original mechanical splice pioneered by Pentair in the 1950s and is suitable for connecting two pieces of rebar in-situ with no bar end preparation required. This system is the premier rebar splice in the world, and as a result, it is the primary splicing method used for nuclear and blast resistant structures. In addition, the LENTON

QUICK WEDGE splice is ideal for repairing or extending small rebars in sizes #4 – #6 (12 mm – 20 mm). This quick and easy to use system is flexible, reliable and economical. Installation is made in seconds by overlapping rebar in the steel sleeve and driving a wedge pin between the bars with a portable hydraulic hand tool. Splices can be made with as little as 3" (76 mm) of exposed dowel. This system is also ideal for adding confinement steel (stirrups) in seismic upgrade applications.

Pentair offers LENTON LOCK for in-situ and repair applications. LENTON LOCK requires no bar end preparation and installs quickly using hand tools found commonly on the job site. Simply tighten the bolts until the head shears off, providing visual verification of proper installation.

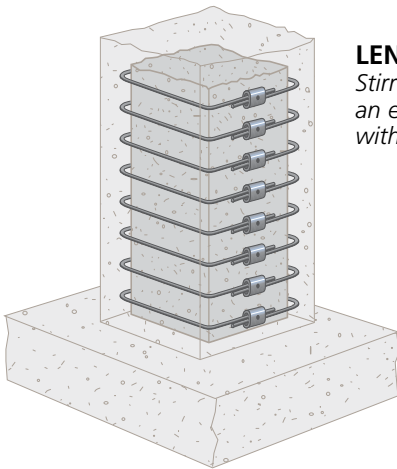

LENTON QUICK WEDGE

Stirrups are joined at two locations around an existing column. The column is encased with additional concrete pour.

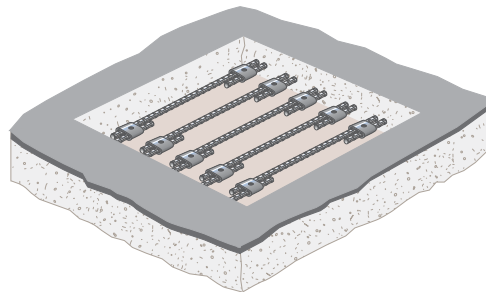

LENTON QUICK WEDGE

Remove sections of deteriorated road slabs or bridge decks. Expose a minimal length of rebar by chipping out additional concrete. New reinforcing steel is joined by an oval shaped coupler. A hydraulic hand tool is used to install a wedge pin between new and old rebar.

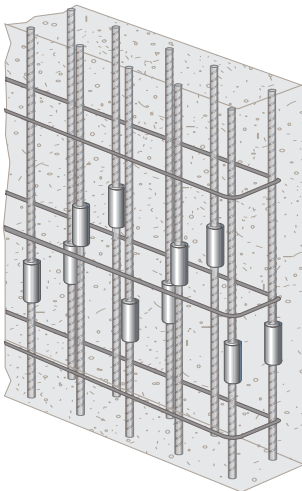

CADWELD

Metal-filled rebar connection used to splice to existing reinforcement bars. No bar end preparation is required.

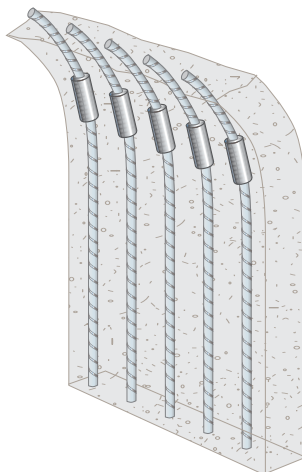

CADWELD

Metal-filled rebar connection designed with an over-sized interior to allow for radius bars.

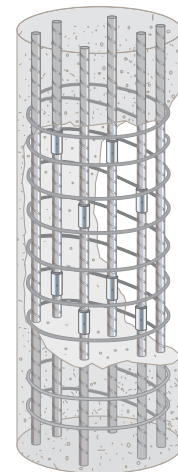

CADWELD

Metal-filled rebar connection used to splice to existing reinforcement bars.

LENTON LOCK

Bolted connection used to splice to existing reinforcement bars. No bar end preparation is required.

LENTON LOCK

Bolted connection used to splice to existing reinforcement bars. No bar end preparation is required.

LENTON Taper Threaded Splicing Systems

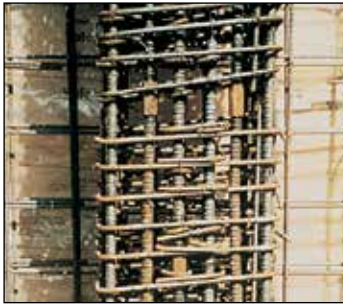

LENTON is the most widely used mechanical splicing system in the world today. And why not? LENTON is unique because it uses a taper thread for assurance of strength, consistency and reliability while simplifying installation.

Designed for use on worldwide standard grades of rebar, LENTON develops the ACI full tension splice strength requirement as per many international standards. No "special" high strength, enlarged thread section, or increased rebar size are necessary, allowing the supply of rebar from multiple sources for maximum cost savings.

- Fastest system to install – accelerating construction schedules.
- Threading at the fabrication shop eliminates installation equipment "problems" at the job site.
- Excellent for future extension applications.
- Contractor can save valuable crane time while gaining flexibility on mechanical splicing schedules.
- Electrostatically epoxy coated couplers are available to maximize corrosion protection.
- Taper thread design eliminates cross threading problems.
- Available in sizes #3 – #18 (10 mm – 57 mm).

LENTON Offers a Coupler for Every Application:

- A Type – Standard bar-to-bar application
- P Type – For bent bar applications
- C Type – For connecting reinforcing bar to structural steel
- S Type – For joining reinforcing bar to standard metric bolt
- D Type – An alternative to hooked bar or as an anchor
- R Type – A Type transition coupler

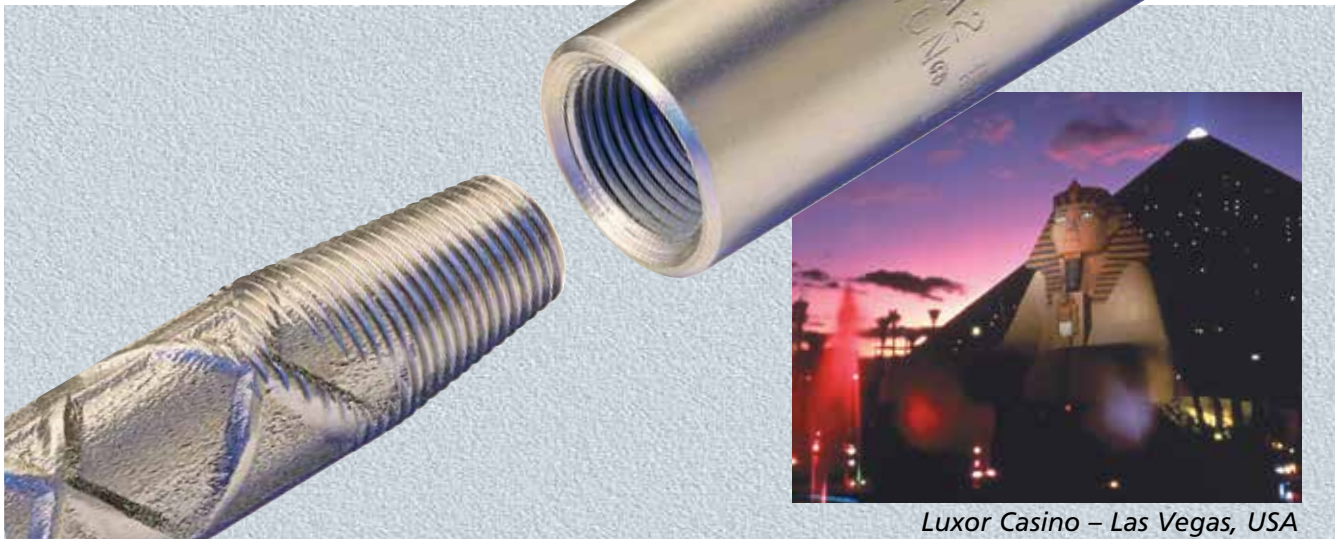
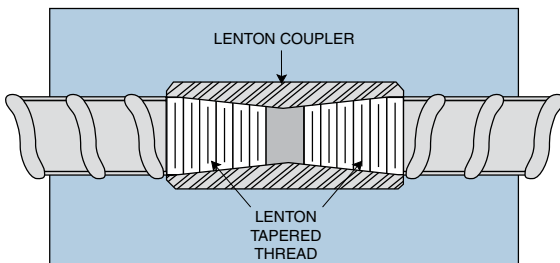
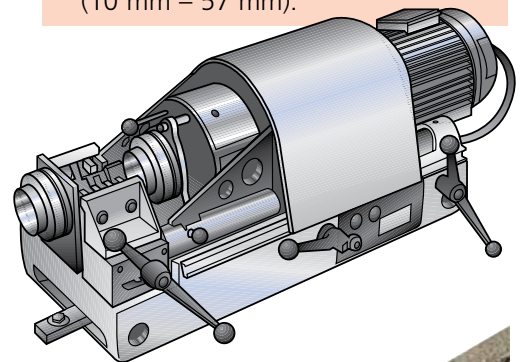

Luxor Casino – Las Vegas, USA

LENTON FORM SAVER

LENTON FORM SAVER solves the age old problem of joining rebar through a concrete form. As an extension of the LENTON product line, LENTON FORM SAVER offers the LENTON advantages with additional features. All couplers are supplied pre-assembled to the rebar with built in internal coupler thread protection to eliminate concrete paste contamination. The plate designed to mount the coupler assembly is pre-attached and features keyed holes to ease attachment to the form.



- Ideal for slip form, jump form, segmental pour and stairwell applications, to name a few.
- Provides job site safety by eliminating protruding dowels.
- Exceeds International Building Code Requirements.
- Quality assurance tensile testing during production runs.
- Available in sizes #4 – #11 (12 mm – 36 mm)

The system eliminates:

- The need to cut holes in expensive form work
- Questionable condition of “bent and rebent” rebar
- Bars breaking during straightening
- Specifying Grade 40 rebar for the application

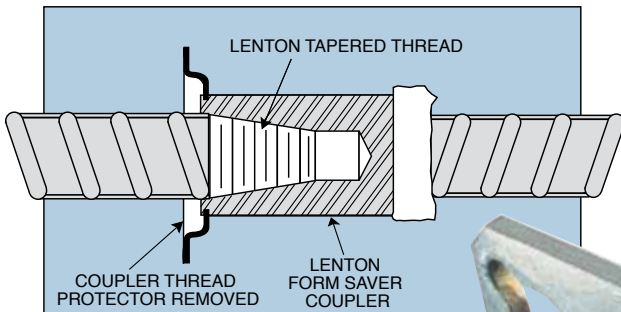

Nationale Nederlanden – Netherlands

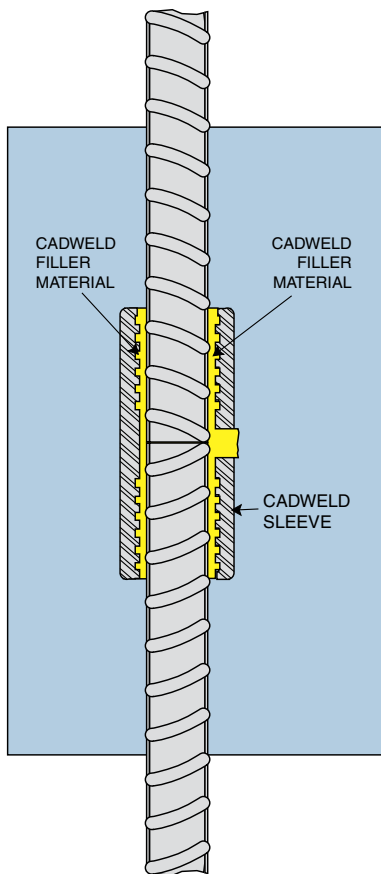

For the most demanding applications, the CADWELD rebar splicing system has earned its reputation as the strongest splice. The primary usage for CADWELD is related to critical structures requiring high safety margins such as blast resistant facilities, pressure vessel applications, or seismic resistance.

CADWELD is a mechanical splice, not a weldment. The system utilizes an internally grooved sleeve working in conjunction with the rebar deformations. Load is transferred from the rebar to the sleeve via CADWELD filler material. The finished connection develops strength and consistency – there is no equal in the industry.

Due to its popularity in critical structures, CADWELD is the world's most tested mechanical splice. Its record includes over 25,000 actual field made tensile tests.

- Consistently develops minimum ultimate strength of the rebar.
- Excellent for joining circumferential bars.
- Simplifies acceleration of splicing schedules.
- Retrofit and repair with short dowels and requires no bar end preparation.
- Available in sizes #4 – #18 (12 mm – 57 mm).



CADWELD rebar splices have been used in over 200 nuclear power plants worldwide.

LENTON QUICK WEDGE



LENTON QUICK WEDGE

A minimal amount of concrete is removed from the existing road way or bridge deck. An oval shaped mechanical lap splice coupler is assembled using a portable hydraulic hand tool.

The LENTON QUICK WEDGE splicing system is designed to deliver a quick and simple method of splicing #4 – #6 (12 mm – 20 mm) bar. Installation is made in seconds by over-lapping rebar in the steel sleeve and driving the wedge pin between the bars with a portable hydraulic hand tool.

LENTON QUICK WEDGE offers fast installation by allowing rebar to be cut to the approximate size that spans between the rebar being joined, doing away with custom cutting and fitting as in butt splicing. Splices can be made with as little as 3" (76 mm) of exposed dowel.

- Minimal dowel lengths eliminate excessive and expensive concrete chipping in retrofit installations.
- "Lapped bar" capability and minimal exposed bar ends make the LENTON QUICK WEDGE system a natural for road/ bridge repair and closure pours.
- The ideal splice system for adding confinement steel (stirrups) in seismic upgrade applications.
- Exceeds characteristic strength requirements in the code.
- Can make up to 100 splices per hour.

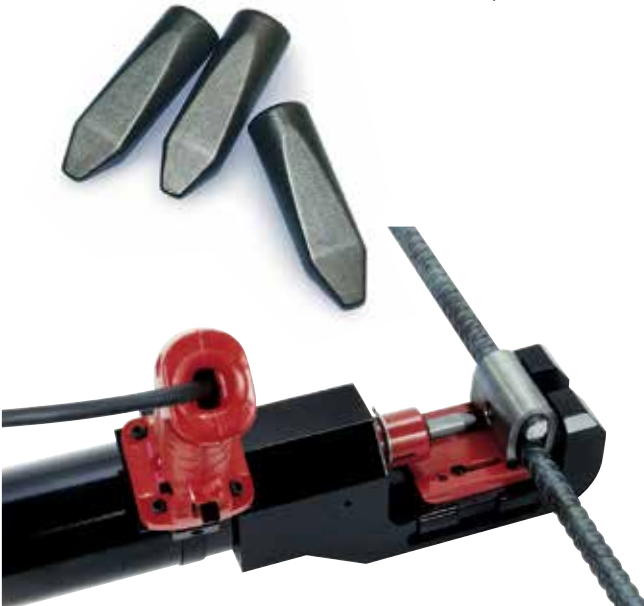

LENTON QUICK WEDGE

Protruding bars from the precast wall are joined using an oval shape coupler. The bars are overlapped and assembled using a hydraulic hand tool. Cast-in-place concrete is poured after the connections are completed.

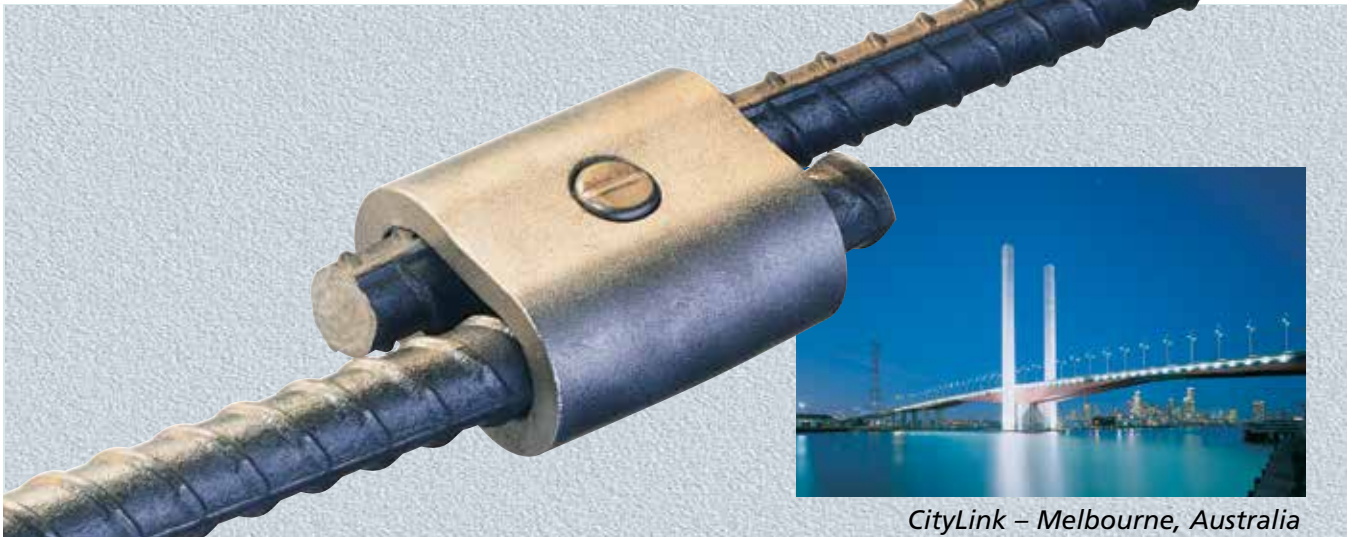

CityLink – Melbourne, Australia

LENTON INTERLOK

For precast construction, Pentair offers the LENTON INTERLOK rebar splicing system. Splices are designed to maintain structural integrity between load bearing precast members such as columns, beams and shear walls. The completed connection exceeds the ACI Building Code Requirement.

LENTON INTERLOK utilizes the LENTON taper threaded system on one end, which has been recognized worldwide for nearly two decades. The opposite end of the sleeve is filled at the jobsite with a specially formulated cementitious filler (grout). A quality connection is assured since both the coupler and filler are supplied by Pentair as a system.

Unlike embedded connections, tensile loads are transferred through the rebar, and are not dependent on the compressive strength of the concrete.

- Maintains structural integrity through precast sections. The reinforcing steel acts as one continuous bar well above 125 percent of yield.
- Unlike embedded connections, tensile loads are transferred through the rebar, and are not dependent on the compressive strength of the concrete.
- The connection is not detrimental to surrounding concrete, since no heat is produced, as in arc-welding.
- No more unsightly and costly patchwork required, creating an aesthetically appealing finish.
- Designed for all rebar sizes from #6 – #18 (20 mm – 57 mm).

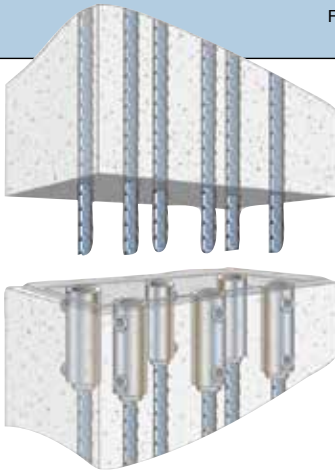
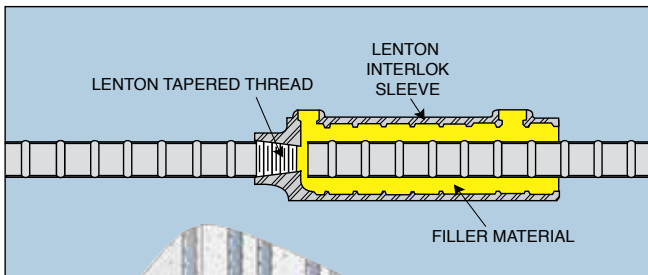

Turner Field – Atlanta, Georgia – USA

LENTON SPEED SLEEVE

For compression only applications, LENTON SPEED SLEEVE is the splice of choice. The system is designed to allow compressive loads to be transferred by aligning square cut rebar to bear on one another. LENTON SPEED SLEEVE is desirable because it can be installed on rebar dowels without the upper bar in place. This feature allows one-man installation and is conducive to prefabricated cage assembly.

- Installation is a one-man operation keeping labor costs down.
- Transition splices can be made with the use of simple adaptor inserts.
- Install with an air or electrically driven impact wrench.
- Fast installation keeps construction on or ahead of schedule.
- Designed for sizes #6 – #18 (20 mm – 57 mm).



The Pentagon – Washington DC, USA

LENTON TERMINATOR

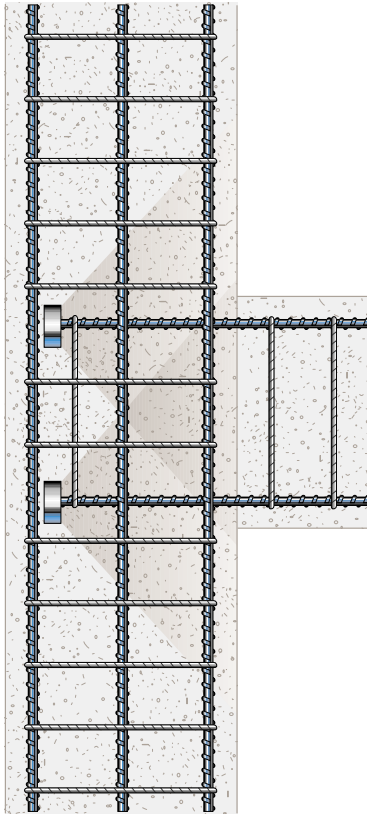

Recent code changes have significantly increased the amount of rebar required, while at the same time, designers are striving for more compact structural elements. This results in rebar congestion and placement problems. Built on the extensive testing conducted for headed anchors, the LENTON TERMINATOR answers these challenges by eliminating the majority of rebar embedment lengths required, while reducing job-site man-hours and related labor costs.

Utilizing the principles of the Shear Cone Theory on which ACI-355 is based, the LENTON TERMINATOR is designed for use on all rebar grades sizes #4 – #18 (12 mm – 57 mm). The LENTON TERMINATOR incorporates the time-tested, field-proven LENTON tapered thread and is supplied through a network of local rebar fabricators. LENTON TERMINATOR is available in both 5x and 10x bar areas.

- 60% less rebar congestion by eliminating the need for hooked rebar embedments.
- Complies with major codes and standards while minimizing embedment lengths to reduce congestion.
- Simplifies concrete placement for better concrete consolidation.
- Offers more embedment options, while allowing greater design flexibility.
- Faster installation lowers the in-place cost.
- Standard product dimensions require minimal detailing.
- Simplifies expansion while allowing for future extensions.



ACI-355 is based on the principles of the Shear Cone Theory

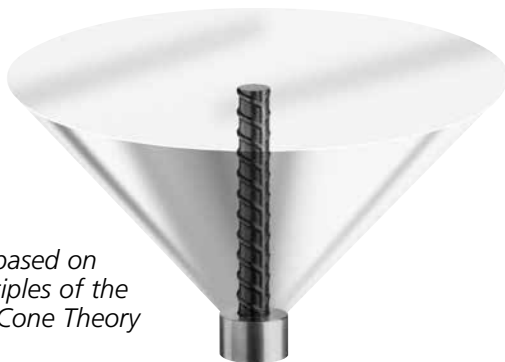

Malampaya Offshore Platform – The Philippines

LENTON LOCK

LENTON LOCK requires no bar-end preparation and is ideal for new construction, repair or retrofit applications. The LENTON LOCK coupler features patented gripping technology that provides for the development of full rebar strength and improved overall structural integrity in tension, compression, stress-reversal and dynamic applications. This innovative mechanical rebar splice is designed for use in column splicing, bridge applications, piling, splicing to protruding dowels cast in concrete, closure pours, beams, chimney construction and other demanding splicing applications.

LENTON LOCK couplers meet or exceed major international building codes and Department of Transportation (DOT) requirements, including CalTrans' Ultimate Splice requirement, IBC®, IAPMO®-UES and ACI® 318 Type 2, DIN EN1992-1-1 and BS EN1992-1-1.

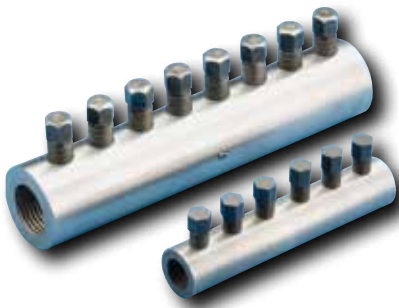

Ideal for in-situ splices, the couplers allow for easy and simple field installation since no bar-end preparation, sawing or swaging is necessary. They can be installed with just a standard wrench or an impact wrench, depending on coupler size. The bolt heads will shear off when proper installation tightness has been reached, which allows for visual inspection.

- Is shorter and smaller in diameter than other bolted splices currently available.
- Works with a variety of standard US and international rebar grades.
- Provides superior fatigue performance.
- Performs like a continuous piece of rebar.
- Works as one-step transition on ASTM (in-lb) and metric rebar.
- Meets slip criteria of less than 0.0039 in (0.10 mm).



Patent no.: 7,107,735 / 7,093,402.
Additional patents in other countries.

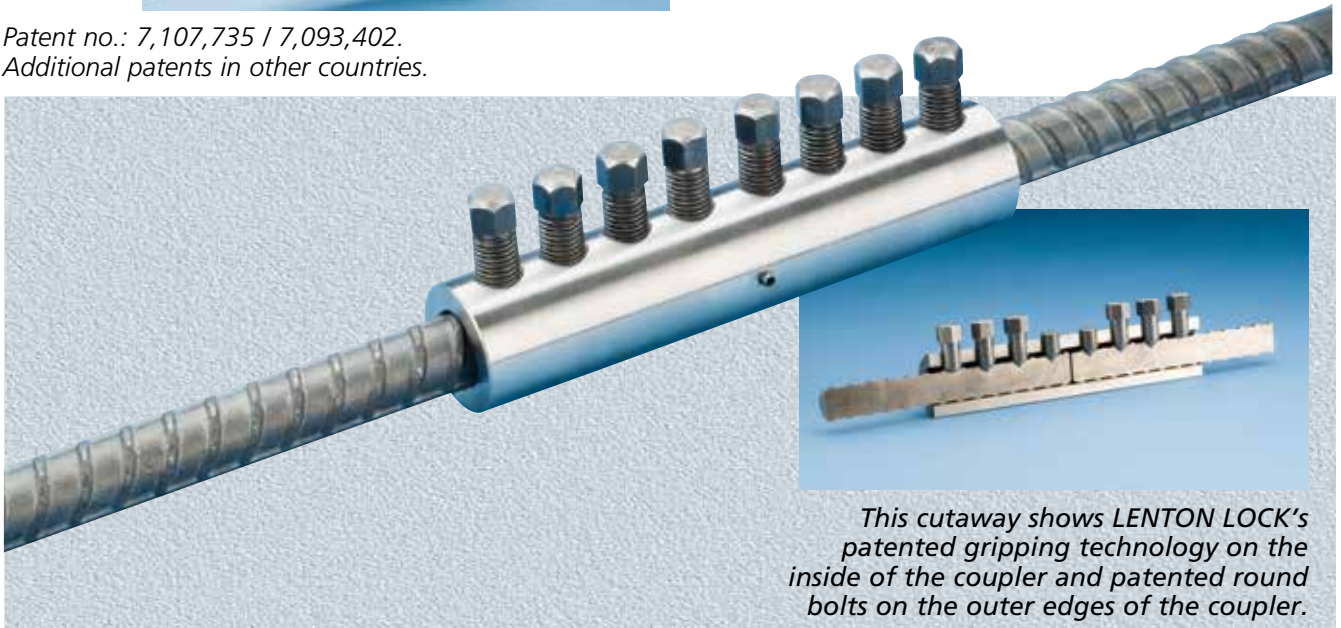

This cutaway shows LENTON LOCK's patented gripping technology on the inside of the coupler and patented round bolts on the outer edges of the coupler.

Put the Pentair Advantage to Work for You

Pentair Engineered Electrical & Fastening Solutions is a leading global manufacturer and marketer of superior engineered products for niche electrical, mechanical and concrete applications. These Pentair products are sold globally under a variety of market-leading brands: ERICO welded electrical connections, facility electrical protection, and rail and industrial products; CADDY fixing, fastening and support products; ERIFLEX low voltage power and grounding connections; and LENTON engineered systems for concrete reinforcement.

For more information on ERICO, CADDY, ERIFLEX and LENTON, please visit erico.pentair.com.



The Rebar Splicing Specialists

The LENTON Rebar Splicing Family



- LENTON Taper Threaded Splices
- LENTON FORM SAVER
- CADWELD
- LENTON INTERLOK
- LENTON QUICK WEDGE
- LENTON SPEED SLEEVE
- LENTON TERMINATOR
- LENTON LOCK



WARNING

Pentair products shall be installed and used only as indicated in Pentair's product instruction sheets and training materials. Instruction sheets are available at www.erico.pentair.com and from your Pentair customer service representative. Improper installation, misuse, misapplication or other failure to completely follow Pentair's instructions and warnings may cause product malfunction, property damage, serious bodily injury and/or death, and void your warranty.

Projects



*Petronas Towers
– Malaysia*



*KPN, Rotterdam
– Netherlands*



*Nationale
Nederlanden
– Rotterdam*



*Control tower, Schiphol Airport
– Amsterdam*

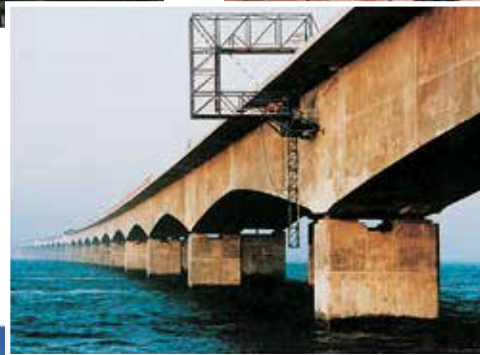

*Storebaelt
West Bridge –
Denmark*

Messturm – Frankfurt



*La Défence
– Paris, France*



*Trianon
– Frankfurt*



F3 - Platform NAM – Rotterdam



www.erico.pentair.com



AUSTRALIA
Phone 1-800-263-508
Fax 1-800-423-091

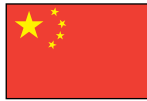

CHINA
Phone +86-21-3430-4878
Fax +86-21-5831-8177



HUNGARY
Phone 06-800-16538
Fax +39-0244-386-107



NORWAY
Phone 800-100-73
Fax 800-100-66



SWITZERLAND
Phone 0800-55-86-97
Fax 0800-55-96-15



BELGIUM
Phone 0800-757-48
Fax 0800-757-60



DENMARK
Phone 808-89-372
Fax 808-89-373



INDONESIA
Phone +62-21-575-0941
Fax +62-21-575-0942



POLAND
Phone +48-71-349-04-60
Fax +48-71-349-04-61



THAILAND
Phone +66-2-267-5776
Fax +66-2-636-6988



BRAZIL
Phone +55-11-3623-4333
Fax +55-11-3621-4066



FRANCE
Phone 0-800-901-793
Fax 0-800-902-024



ITALY
Phone 800-870-938
Fax 800-873-935



SINGAPORE
Phone +65-6-268-3433
Fax +65-6-268-1389



UNITED ARAB EMIRATES
Phone +971-4-881-7250
Fax +971-4-881-7270



CANADA
Phone +1-800-677-9089
Fax +1-800-677-8131



GERMANY
Phone 0-800-189-0272
Fax 0-800-189-0274



MEXICO
Phone +52-55-5260-5991
Fax +52-55-5260-3310



SPAIN
Phone 900-993-154
Fax 900-807-333



UNITED KINGDOM
Phone 0808-2344-670
Fax 0808-2344-676



CHILE
Phone +56-2-370-2908
Fax +56-2-369-5657



HONG KONG
Phone +852-2764-8808
Fax +852-2764-4486



NETHERLANDS
Phone 0800-0200-135
Fax 0800-0200-136



SWEDEN
Phone 020-790-908
Fax 020-798-964



UNITED STATES
Phone 1-800-753-9221
Fax +1-440-248-0723