

CI/SIB	(21.9)	Xt6	
September 2013			

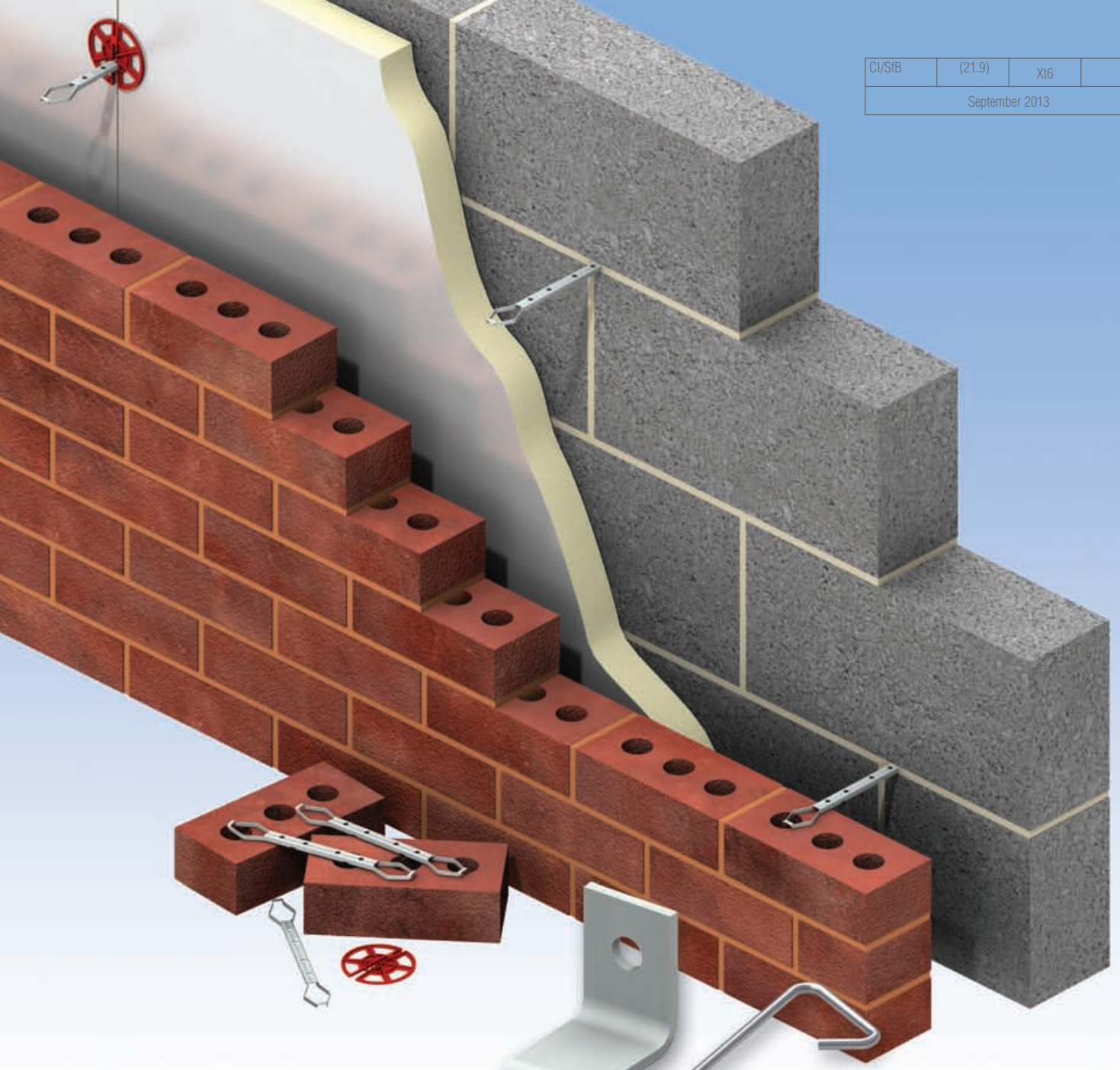

Wall Ties and Restraint Fixings for the Construction Industry

CE
BS EN 845-1

Ancon[®]
BUILDING PRODUCTS

Wall Ties and Restraint Fixings

For building with brick, block and stone

Wall ties and restraint fixings are an essential element in the stability of masonry panels.

Ancon manufactures fixings in a variety of lengths and types for restraining brickwork, blockwork and stonework. Restraints can be fixed to concrete and structural steelwork as well as any type of masonry.

Products are manufactured from stainless steel unless stated otherwise.

The range of standard ties provides a solution for all types of wall construction and many products can be delivered in 24 hours. These items are shown in *red italics*.



Dedicated sales and technical support



Distributors nationwide



Cavity Wall Tie Product Selector App



CPD Seminars available



CE marking to BS EN 845-1



Product information in NBS format



ISO 9001, ISO 14001 & OHSAS 18001



Contents

<u>Cavity Wall Tie Selection</u>	<u>4-6</u>	<u>Vertical Movement Joints</u>	<u>17</u>
<u>Installation Guidance</u>	<u>7</u>	<u>Standard Wall Ties</u>	<u>18</u>
<u>Ties for Brick-to-Block Construction</u>	<u>8-9</u>	<u>Bespoke Wall Tie References</u>	<u>19</u>
<u>Ties for Cavities over 150mm</u>	<u>10</u>	<u>Non-Drill Fixings for Steelwork</u>	<u>20-21</u>
<u>Slip Brick Ties</u>	<u>10</u>	<u>Head Restraints & Sliding Anchors</u>	<u>22-23</u>
<u>Ties for Steel Studwork</u>	<u>11</u>	<u>Wall Starter Systems</u>	<u>24-25</u>
<u>Ties for Thin-Joint Blockwork</u>	<u>12</u>	<u>Restraints for Stone Cladding</u>	<u>26-28</u>
<u>Ties for Bubble Foil Insulation</u>	<u>13</u>	<u>Remedial Wall Ties</u>	<u>29-30</u>
<u>Ties for Timber Frames</u>	<u>13</u>	<u>Staifix-Thor Helical Crack Stitching Kit</u>	<u>31</u>
<u>Frame Cramps and Channel Ties</u>	<u>14-16</u>	<u>Other Ancon Products</u>	<u>31</u>

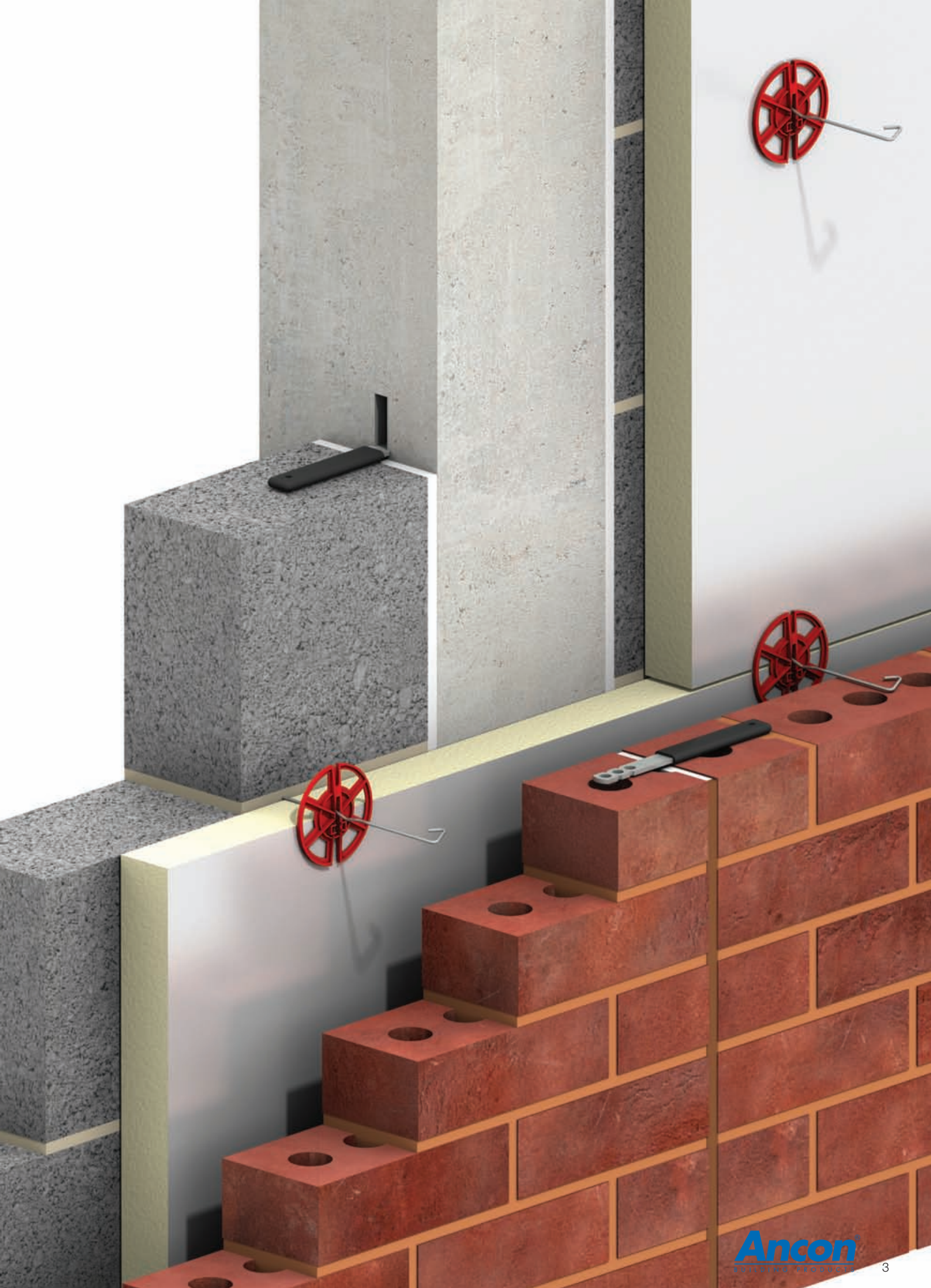

Wall Ties and Restraint Fixings



© Hazle McCormack Young



© Irvine Whitlock



© Green Building Store

Cavity Wall Tie Selection

The selection and spacing of wall ties depend on many factors. These include type of masonry to be tied, cavity width, type and height of building and geographical location. There are several documents which need to be consulted and are summarised here.

Eurocode 6 – Design of Masonry Structures (BS EN 1996-1-1: 2005)

In 2010, Eurocode 6 became the main code for the design of reinforced and unreinforced masonry. Eurocode 6 refers to EN 845-1 for wall ties and sets the density of ties per square metre based on the declared value of the tie. The material factor of 3.0 for detailed calculations is specified in the UK National Annex.

BS EN 845-1: 2003 +A1: 2008 Specification for Ancillary Components for Masonry – Part 1: Ties, Tension Straps, Hangers and Brackets

This European Standard specifies the requirements for wall ties used for interconnecting masonry and for connecting masonry to beams, columns or other parts of the building. Materials, tolerances, tie variations and the requirements for declared values, are all covered in this standard. For tie Types and qualifying criteria refer to PD 6697: 2010.

CE Marking

Construction products which fall within the scope of a harmonised European Standard must carry CE marking before they can legally be sold in the European Economic Area. For wall ties, the harmonised standard is BS EN 845-1 detailed above. Ancon complies with all requirements of this legislation and our literature identifies the products affected with a CE logo. For more information or to download a Declaration of Performance, please visit www.ancon.co.uk/CE.



PD 6697: 2010 Recommendations for the design of masonry structures to BS EN 1996-1-1 and BS EN 1996-2

Published Document 6697 contains non-contradictory, complementary information from the withdrawn British Standard BS 5628, which was not included in the BS EN 1996 series.

It includes recommendations on tie lengths, embedment, density, material and positioning. Masonry-to-masonry ties are classified as Types 1 to 4; the relevant classification is determined by strength, function and use. Minimum declared values for tension and compression are listed on page 5 for each tie Type.

Approved Document E: Resistance to the Passage of Sound

This document specifies the acoustic performance requirements of ties suitable for use in separating walls (Type A) and external walls (Type B) of new build dwellings.

Type A ties must have a measured dynamic stiffness of $<4.8\text{MN/m}^3$ for the specified minimum cavity, at a standard density. Type A ties in this literature are indicated by this logo e.g. Staifix HRT4, page 8.



All Ancon ties which cross a cavity meet the requirements of Type B.

BS 5628, Code of Practice for the Use of Masonry

BS 5628 was withdrawn when the Eurocode became the accepted National code in March 2010. The majority of information in this British Standard has been reproduced in PD 6697: 2010.

BS 5268-6.1: 1996 (Incorporating Amendments No. 1 and 2): Structural use of timber – Dwellings not exceeding seven storeys

BS 5268 provides recommendations for wall ties for timber framed buildings. Information is provided for the type of structure, location, embedment, density and positioning. These ties are classified as Types 5 to 7; minimum declared values in tension and compression are listed for Types 5 and 6.

Although BS 5268 was officially withdrawn on the full implementation of Eurocodes in March 2010, timber frame wall ties should continue to be selected from Types 5 to 7 as given in Annex B of BS 5268 Part 6.1: 1996, until further guidance is made available.

Wind Code Variations

Masonry wall ties should be selected from the Types in PD 6697 and timber frame wall ties should be selected from the Types in BS 5268. These two documents use different Wind Codes.

The maximum wind speeds referred to in PD 6697 are based on ten minute return periods according to the current Wind Code BS EN 1991-1-4: 2005.

The geographical locations in BS 5268-6.1 are based on hourly return period wind speeds according to BS 6399-2: 1997.

Wall tie Types and the appropriate wind speed maps are shown on page 5.

Wall Tie Product Selector

Available on the Ancon website or as an App, this easy to use product selector enables selection of the most appropriate wall ties for your application. Simply answer a series of multiple choice questions about wall type, inner leaf construction, building type and height, insulation and cavity width, to arrive at the required solution.



App available for iPhone and Android devices

Minimum Requirements for Wall Ties to PD 6697: 2010 (Table 12) and BS 5268-6.1: 1996 (Annex B)

Type of Tie	Minimum Mortar Class and Designation	Tensile Load Capacity (N)	Compressive Load Capacity (N)
1	M12 (i) M2 (iv)	5000 2500	5000 2500
2	M2 (iv)	1800	1300
3	M2 (iv)	1100	800
4	M2 (iv)	650	450
5	M4 (iii)	600	425
6	M4 (iii)	630	440
7	M4 (iii)	To be declared by the Wall Tie Manufacturer	

Masonry-to-Masonry Wall Tie Types to PD 6697: 2010

Type	Application	Density	Maximum Building Height	Geographical Location
Type 1	Heavy duty tie suitable for most building sizes and types. Not very flexible and not recommended for applications where there is expected to be excessive differential movement between leaves	2.5 ties/m ² 3-4 ties/m ² at unbonded edges	Any Height	Suitable for most sites. However, for relatively tall or unusually shaped buildings in vulnerable areas, the tie provision should be calculated
Type 2	General purpose tie for domestic and small commercial buildings.	As Type 1	15m	Suitable for flat sites where the basic wind speed is up to 31m/s and altitude is not more than 150m above sea level
Type 2 ties are suitable for use outside the parameters stated e.g. sites over 150m above sea level, buildings exceeding 15 metres etc, if shown to be adequate by calculation. Contact Ancon for more information.				
Type 3	Basic wall tie generally as Type 2 above	As Type 1	15m	Suitable for flat sites where the basic wind speed is up to 27m/s and altitude is not more than 150m above sea level
Type 4	Light duty wall tie suitable for box-form domestic dwellings with leaves of similar thickness	As Type 1	10m	Suitable for flat sites in towns and cities where the basic wind speed does not exceed 27m/s and altitude is not more than 150m above sea level

Note: Refer to PD 6697: 2010 and BS EN 1991-1-4: 2005 for complete information.

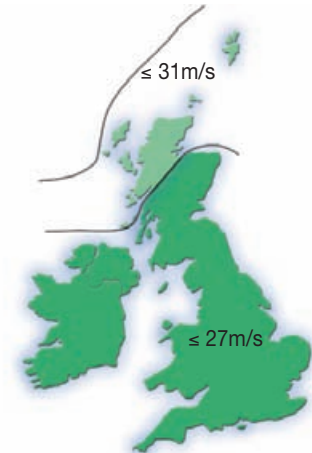

Wind speed information taken from BS EN 1991-1-4: 2005 for use with PD 6697: 2010.

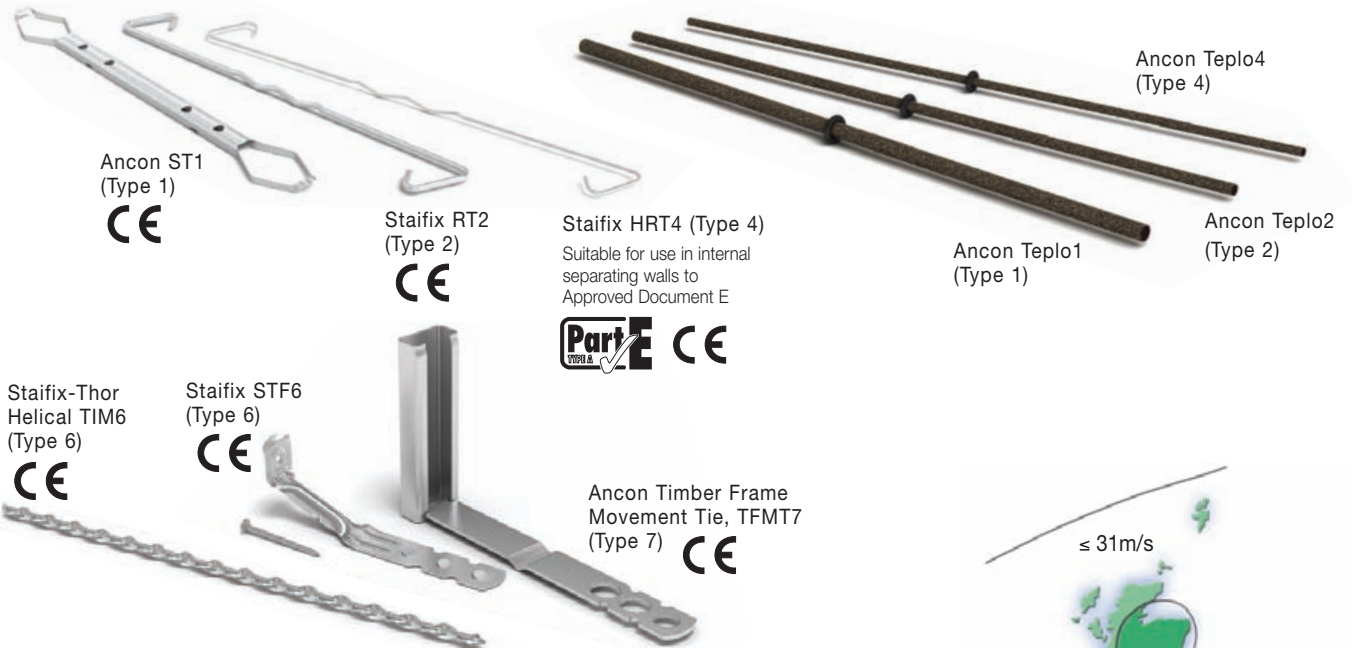

Masonry-to-Timber Tie Types to BS 5268-6.1: 1996

Type	Application	Density	Maximum Building Height	Geographical Location
Type 5	Timber frame tie suitable for domestic houses and industrial/commercial developments of up to three storeys	4.4 ties/m ² 3-4 ties/m at unbonded edges	15m	Suitable for flat sites in towns and cities where the basic wind speed does not exceed 25m/s and altitude is not more than 150m above sea level
Type 6	As Type 5 but suitable for developments of up to four storeys	As Type 5	15m	Suitable for flat sites in towns and cities where the basic wind speed does not exceed 25m/s and altitude is not more than 150m above sea level
Type 7	As Type 5 but suitable for developments of between five and seven storeys, being designed to accommodate the increased vertical differential movement	Calculated for actual performance required for each site location	18m	Calculated for actual performance required for each site location

Note: Refer to BS 5268-6.1: 1996 and BS 6399-2: 1997 for complete information.

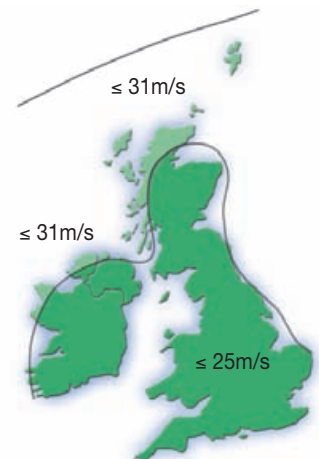

Wind speed information taken from BS 6399-2: 1997 Code of Practice for Wind Loads for use with BS 5268-6.1: 1996.

Wall Ties and Restraint Fixings

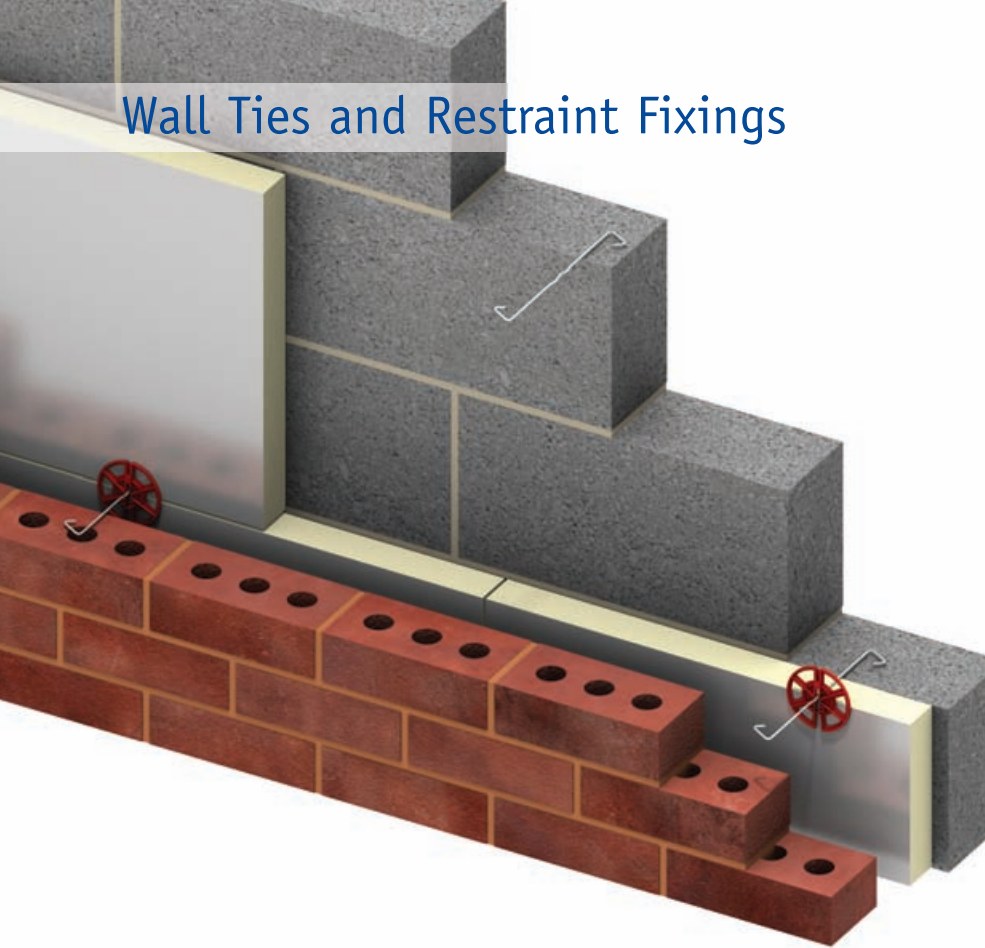

Density & Positioning of Ties

PD 6697: 2010 recommends that for walls in which both leaves are 90mm or thicker, ties should be used at not less than 2.5 per square metre (900mm horizontal x 450mm vertical centres). Ties should be evenly distributed over the wall area, except around openings, and should preferably be staggered.

At vertical edges of an opening, unreturned or unbonded edges, and vertical expansion joints, additional ties should be used at a rate of one per 300mm height, located not more than 225mm from the edge.

A typical layout is shown below. Various details incorporating debonding ties at vertical movement joints are shown on page 17.

Typical Layout of Wall Ties Indicating Maximum Spacing

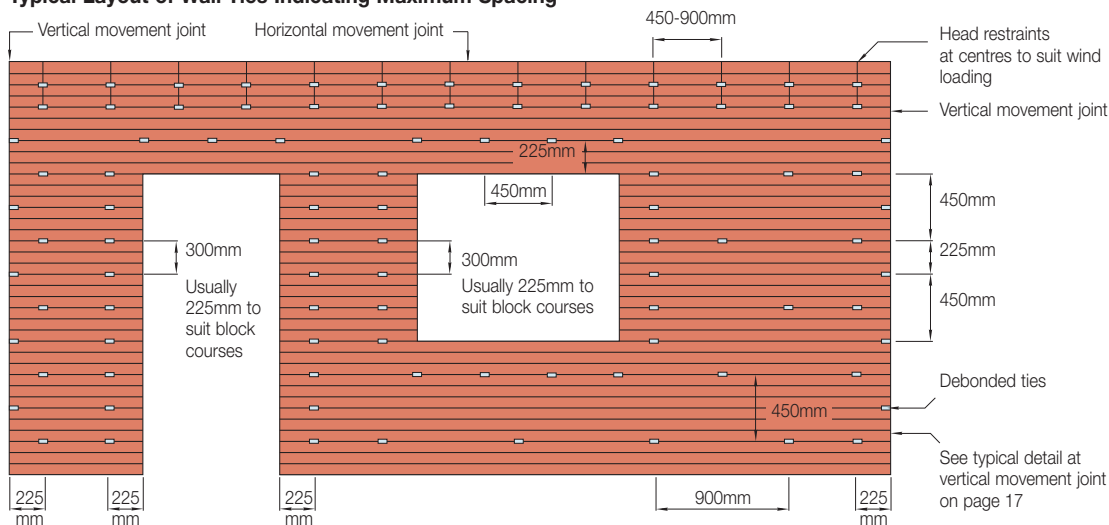

Standard spacing for cavity brickwork 900mm x 450mm centres in a staggered pattern (2.5 ties per square metre)

Length of Tie & Embedment

Wall ties should be of the correct length to ensure they are properly embedded in the masonry. The tie should have a minimum embedment of 50mm in each leaf but also take site tolerances into account for both cavity width and centring of the tie. For this reason Ancon suggests tie lengths which achieve an embedment of between 62.5mm and 75mm.

Recommended lengths to suit various cavity widths are shown in the table for masonry-to-masonry wall ties.

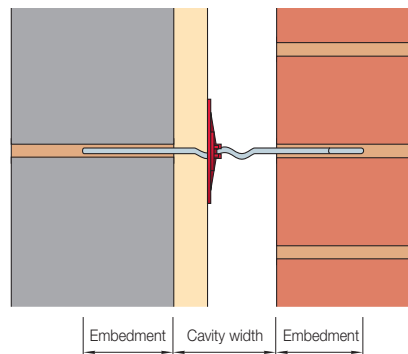

Embedment of Wall Ties

Recommended Lengths of Masonry / Masonry Wall Ties

Cavity Width (mm)	Length of Wall Tie (mm)	Available Wall Ties
50-75	200	HRT4/RT2/ST1/Teplo
76-100	225	HRT4/RT2/ST1/Teplo
101-125	250	HRT4/RT2/ST1/Teplo
126-150	275	HRT4/RT2/ST1/Teplo1/Teplo2
151-175	300	ST1/Teplo2/DI/Two-Part Tie
176-200	325*	Teplo2/Two-Part Tie
201-225	350*	Teplo2/Two-Part Tie
226-250	375*	Teplo2/Two-Part Tie
251-275	400*	Teplo2/Two-Part Tie
276-300	425*	Teplo2/Two-Part Tie

*Lengths for Teplo 2. For the Two-Part Tie refer to page 10

Installation Guidance

Wall ties are important to the stability of masonry and failure to install them correctly may lead to damp penetration, cracking or even the collapse of walls.

Wall ties should be pressed down in fresh mortar. They should be surrounded by mortar and not simply positioned directly onto masonry with mortar placed around them.

Ideally, ties should be installed with a slight fall to the outer leaf, not towards the inner leaf as this could provide a path for moisture to cross the cavity.

The drip part of the tie should point downward and be positioned near the centre of the open cavity. Ties with multiple drips, like the Staifix RT2, can often be positioned centrally as part of the drip will normally be near the centre of the open section of a partial fill cavity. 'O rings' as used on the TeploTie should be moved along the shank to the open cavity.

Installed ties should be clear of mortar droppings to allow the drip to function and prevent water from crossing to the inner leaf of masonry.

The practice of bending up installed wire ties should be discouraged. This can adversely affect the performance of the tie and weaken the embedment in the inner leaf. Rigid ties like the Ancon SD1 and ST1 should never be bent on site.

To ensure cavity wall ties are effective at tying the leaves together they should be installed as the inner leaf is constructed and not simply pushed into a joint. There is a risk of injury if wall ties are left protruding from a single wall leaf before the second leaf is constructed. Site managers should make all workers and visitors aware of this risk.

To reduce the risk of injury, Ancon's stainless steel wall ties feature rounded safety ends and Ancon TeploTie wall ties are supplied with bright plastic end caps. These end caps should be applied loosely to the outer end of a TeploTie as work on the first leaf progresses and must be removed before the tie is built into the second leaf.

Ancon recommends both leaves of a cavity wall are built simultaneously to eliminate any risk of injury from protruding ties.

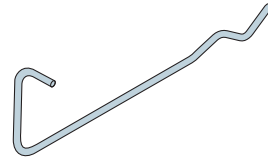

Staifix Safety End

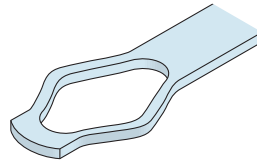

Ancon Spread Safety End

Ancon frame ties and channel ties are manufactured with a non-spread safety end allowing the use of a debonding sleeve. This type of safety end reduces the variety of ties required on site.

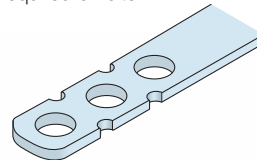

Ancon Non-Spread Safety End

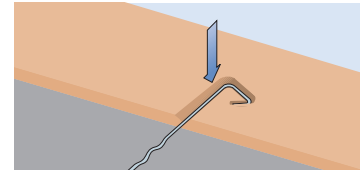

Wall ties should be pressed down in, and then surrounded by, fresh mortar.

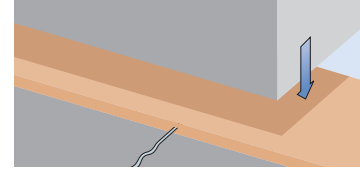

To ensure cavity wall ties are effective at tying the leaves together they should be installed as the inner leaf is constructed and not simply pushed into a joint.

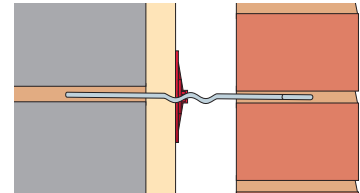

Ties should be installed with a slight fall to the outer leaf, never towards the inner leaf as this could provide a path for moisture to cross the cavity.

Wall Ties with Insulation Retaining Clips

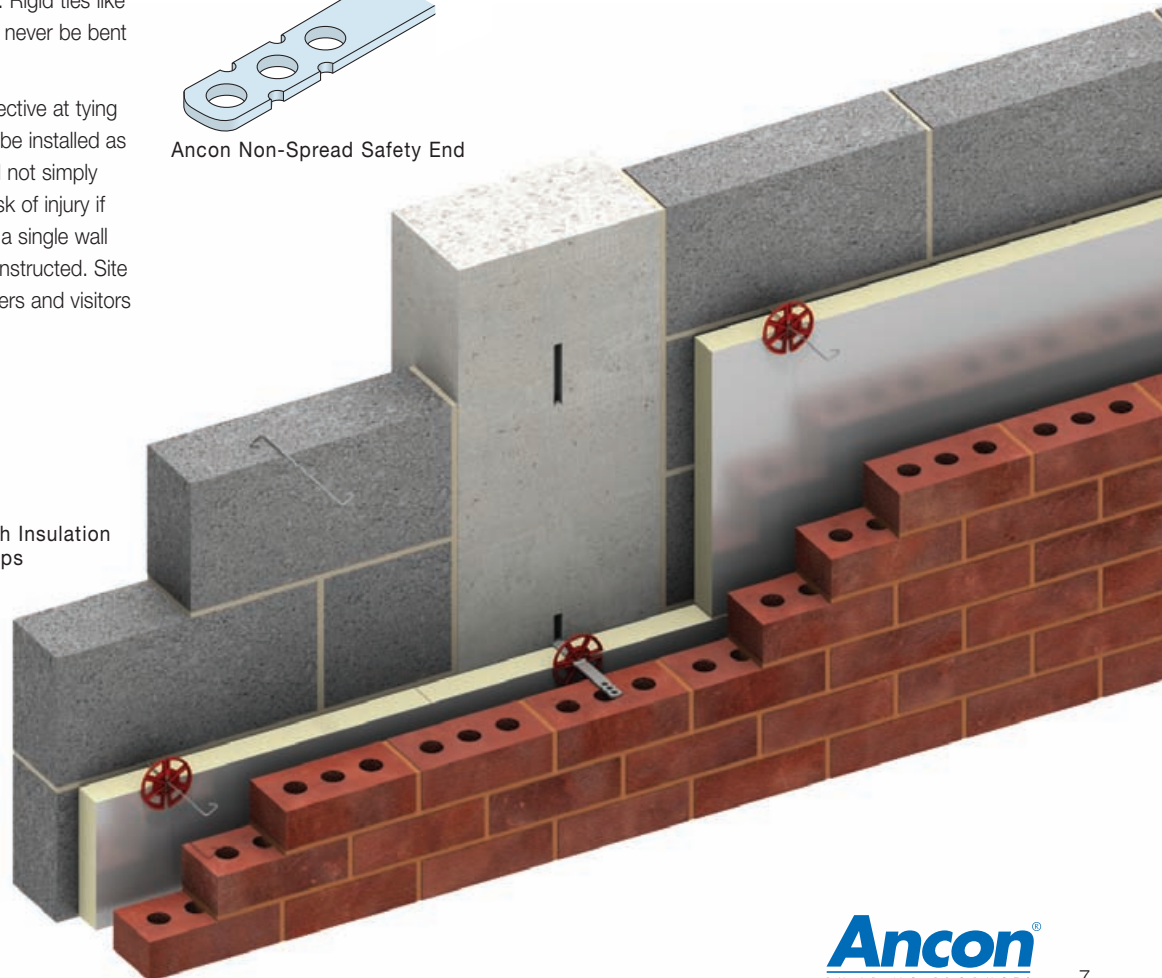

Wall Ties and Restraint Fixings



Wall Ties to PD 6697 for Brick-to-Block Construction

Ancon ST1 Type 1 Tie (Masonry Heavy Duty)

The Ancon ST1 is suitable for cavities from 50mm to 175mm and can be used for all types of buildings of any height, anywhere in the British Isles. The section that spans the cavity has a series of holes to provide water drips. The ST1 has a measured dynamic stiffness of $<113\text{MN/m}^3$ that meets the performance requirement of Approved Document E for use in external masonry walls. For internal separating walls of new-build attached dwellings see HRT4.

Staifix RT2 Type 2 Tie (Masonry General Purpose)

The Staifix RT2 is a general purpose tie. It is suitable for cavities from 50mm to 150mm and can be used for domestic houses and small commercial buildings up to 15 metres in height (see page 5 for geographical restrictions). In many cases, Staifix RT2 wall ties can be used in buildings greater than 15 metres if shown to be adequate by calculation. For further information please contact Ancon's Technical Services Team. The Staifix RT2 has BBA approval and meets the technical requirements of the NHBC. The RT2 has a measured dynamic stiffness of $<113\text{MN/m}^3$ that meets the performance requirement of Approved Document E for use in external masonry walls. For internal separating walls of new-build attached dwellings see HRT4.

Staifix HRT4 Type 4 / Type A Tie (Masonry Light Duty)

The Staifix HRT4 is available for cavities from 50mm to 150mm. As a Type 4 tie it is suitable for use in external walls of domestic houses up to 10 metres in height (see page 5 for geographical restrictions).

The Staifix HRT4 has BBA approval and meets the technical requirements of the NHBC.

The HRT4 is also a Type A tie for separating walls of any height. Independent tests have proven the Staifix HRT4 has a measured dynamic stiffness of $<4.8\text{MN/m}^3$ at a cavity of 50-100mm and 125-150mm and is therefore suitable for internal separating (party) walls of new-build attached dwellings with these cavities. The HRT4 can be used with all approved robust details for cavity masonry separating walls, whether traditional or thin-joint blockwork. Use of these details eliminates the need for pre-completion sound testing.



Ancon ST1, Stainless Steel

- 200mm for 50-75mm cavities
- 225mm for 76-100mm cavities
- 250mm for 101-125mm cavities
- 275mm for 126-150mm cavities
- 300mm for 151-175mm cavities

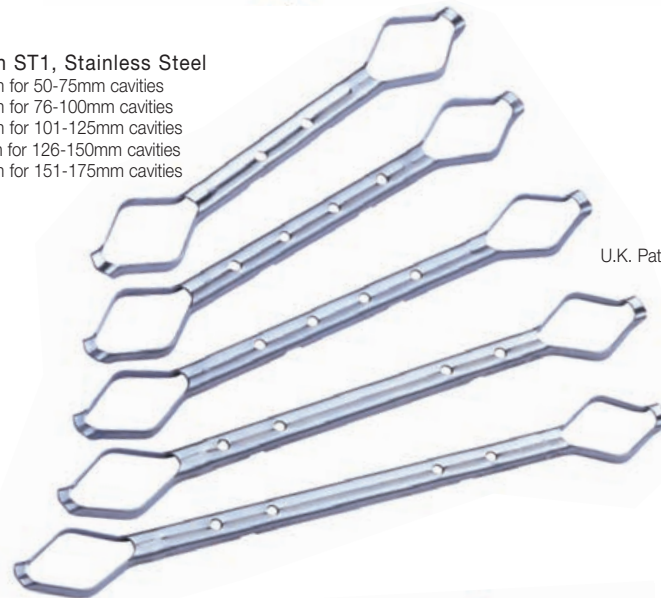

U.K. Patent Nos. 2 255 358
2 260 348
2 260 349



Staifix RT2, Stainless Steel

- 200mm for 50-75mm cavities
- 225mm for 76-100mm cavities
- 250mm for 101-125mm cavities
- 275mm for 126-150mm cavities



Patent Nos. GB 2359831
IE 83574



Staifix HRT4, Stainless Steel

- 200mm for 50-75mm cavities
- 225mm for 76-100mm cavities
- 250mm for 101-125mm cavities
- 275mm for 126-150mm cavities

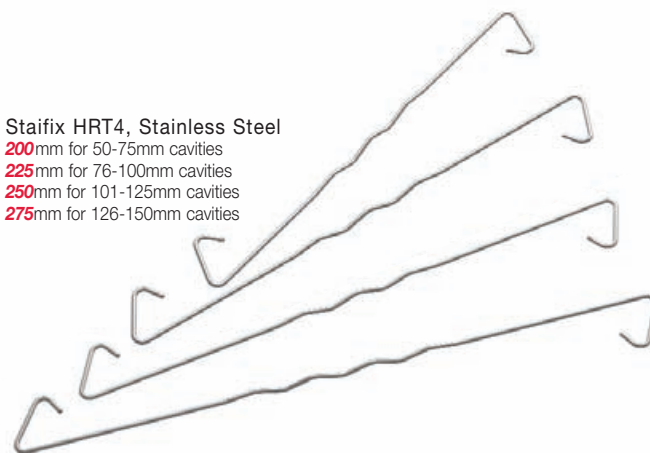

Patent Nos. GB 2359831
IE 83574



Ancon TeploTie

The Ancon TeploTie is suitable for cavities from 50mm to 300mm and is manufactured from pultruded basalt fibres. This material has a thermal conductivity of only 0.7W/mK which can be shown in U-value calculations to reduce insulation thickness and wall footprint. A sand finish provides excellent mortar key.

The Ancon range of TeploTies comprises Teplo1 (Type 1), Teplo2 (Type 2) and Teplo4 (Type 4). Please refer to page 5 for further details on the suitability of each wall tie. Due only to the testing completed to date, the use of Type 1 TeploTies is restricted to buildings up to 18m in height. Contact Ancon for the latest information on this test programme.

Ancon TeploTies have BBA approval and meet the technical requirements of the NHBC. They also meet the performance requirement of Approved Document E for use in external masonry walls. For internal separating walls of new-build attached dwellings see HRT4.

The TeploTie is exclusive to Ancon in the UK and Ireland. It has already been used on many ultra energy efficient buildings including the first certified PassivHaus to be built with traditional masonry cavity walls and the first retrofit to be built to Level 6 (Zero Carbon) of the Code for Sustainable Homes.

TeploTies can be resin-fixed in remedial and retrofit applications. Further details are shown on page 29-30.

Low Thermal Conductivity Wall Ties

Wall ties are an essential element in the strength and stability of cavity walls, but by crossing the cavity they act as a thermal bridge between the internal and external leaves. The ties featured here on pages 8-9 form Ancon's Low Thermal Conductivity range; ties which minimise heat loss and improve the energy-efficiency of a masonry wall. The effect Ancon's high tensile wire wall ties have on heat transfer is negligible and, with a thermal conductivity of only 0.7W/mK, the Ancon TeploTie is the most thermally-efficient wall tie on the market and can be excluded from u-value calculations.

For the accurate calculation of a wall's U-value it is important to use the correct information for the wall ties. Using the actual cross-sectional area and thermal conductivity value of a wall tie, rather than allowing a program to apply default values, can make a considerable difference to the calculated U-value. Default values will over-estimate the effect of an Ancon Wall Tie.

Ancon Teplo1, Basalt-Fibre

200mm for 50-75mm cavities
225mm for 76-100mm cavities
250mm for 101-125mm cavities
275mm for 126-150mm cavities

Ancon Teplo2, Basalt-Fibre

200mm for 50-75mm cavities
225mm for 76-100mm cavities
250mm for 101-125mm cavities
275mm for 126-150mm cavities
300mm for 151-175mm cavities
325mm for 176-200mm cavities
350mm for 201-225mm cavities
375mm for 226-250mm cavities
400mm for 251-275mm cavities
425mm for 276-300mm cavities

Ancon Teplo4, Basalt-Fibre

200mm for 50-75mm cavities
225mm for 76-100mm cavities
250mm for 101-125mm cavities

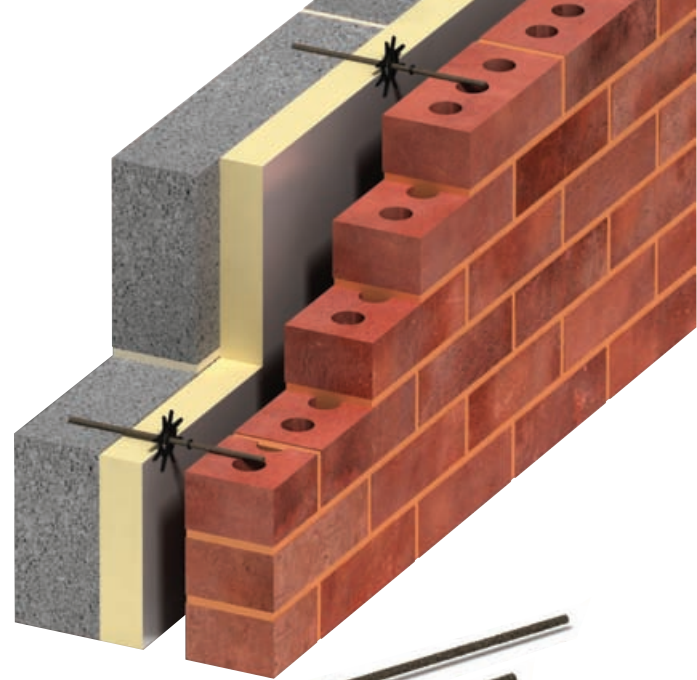

Ancon Teplo4
(Type 4)

Ancon Teplo2
(Type 2)

Ancon Teplo1
(Type 1)



Cross-Sectional Areas and Thermal Conductivity of Ancon Wall Ties

Tie Reference	Tie Length (mm)	Cavity Width (mm)	Tie Type to PD 6697	Area (mm ²)	Thermal Conductivity* (W/mk)
ST1	200	50-75	1	19.5	17
	225	76-100	1	19.5	17
	250	101-125	1	19.5	17
	275	126-150	1	23.4	17
	300	151-175	1	23.4	17
RT2	200	50-75	2	7.5	17
	225	76-100	2	7.5	17
	250	101-125	2	8.6	17
HRT4	275	126-150	2	10.2	17
	200	50-75	4	3.5	17
	225	76-100	4	4.2	17
Teplo1	250	101-125	4	6.2	17
	275	126-150	4	6.2	17
	200	50-75	1	38.5	0.7
Teplo1	225	76-100	1	38.5	0.7
	250	101-125	1	38.5	0.7
	275	126-150	1	38.5	0.7
	200	50-75	2	19.6	0.7
Teplo2	225	76-100	2	19.6	0.7
	250	101-125	2	19.6	0.7
	275	126-150	2	28.3	0.7
	300	151-175	2	28.3	0.7
	325	176-200	2	28.3	0.7
	350	201-225	2	38.5	0.7
	375	226-250	2	38.5	0.7
Teplo4	400	251-275	2	38.5	0.7
	425	276-300	2	38.5	0.7
	200	50-75	4	12.6	0.7
	225	76-100	4	12.6	0.7
	250	101-125	4	12.6	0.7

Note: BS EN ISO 6946 permits the corrections due to wall ties, air gaps etc to be omitted, if the corrections amount to less than 3% of the uncorrected U-value of the element. * Wall Ties with a thermal conductivity of less than 1.0W/mK are excluded from U-value calculations to EN ISO 6946, irrespective of cross-sectional area.

Wall Ties and Restraint Fixings

Ties for Cavities over 150mm

Ancon Two-Part Tie

Cavities exceeding 150mm are sometimes required. This necessitates longer ties which can be difficult to balance and keep horizontal when built into the inner leaf. Alternatively, the Ancon Two-Part Tie has one section built into the blockwork; the other section is then fixed as the outer leaf is built. An embedment of 75mm is required at each end. The inner tie is usually manufactured in lengths of 170mm with variation in the cavity width being accommodated by the length of the outer section. Where insulation thickness is in excess of 60mm, the inner section should be longer than the standard 170mm to ensure the connection between the two parts is made in the open cavity.

Ancon Two-Part Ties sustain loads which exceed the requirements for a Type 2 tie to PD 6697 for cavities up to 300mm. Type 3 performance is achieved at the standard tie spacing for wider cavities up to 400mm.

To specify or order this tie simply quote 'Ancon Two-Part Tie to suit ___mm cavity with an insulation thickness of ___mm'. The black TJ Insulation Retaining Clip is recommended for use with the inner section.

Recommended Fixing Centres for Two-Part Ties

Cavity (mm)	Type 1	Type 2	Type 3
150-300	600x450	900x450	900x450
301-400	375x450	750x450	900x450

Note: Centres shown achieve equivalent tie type performances to PD 6697: 2010 6.2.2.5 Table 12. See page 5 for details.

Ancon TeploTie

Ancon Teplo2 (Type 2) wall ties are available to suit cavities up to 300mm. They have a thermal conductivity of only 0.7W/mK, are BBA approved and meet the technical requirements of the NHBC. These ties are suitable for use with partial-fill and full-fill cavities.

Wall Tie Reference	PD 6697 Type	Length (mm)	Cavity Range (mm)
Teplo2	2	200	50-75
Teplo2	2	225	76-100
Teplo2	2	250	101-125
Teplo2	2	275	126-150
Teplo2	2	300	151-175
Teplo2	2	325	176-200
Teplo2	2	350	201-225
Teplo2	2	375	226-250
Teplo2	2	400	251-275
Teplo2	2	425	276-300

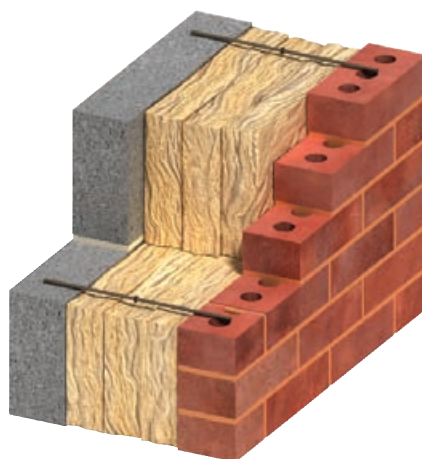
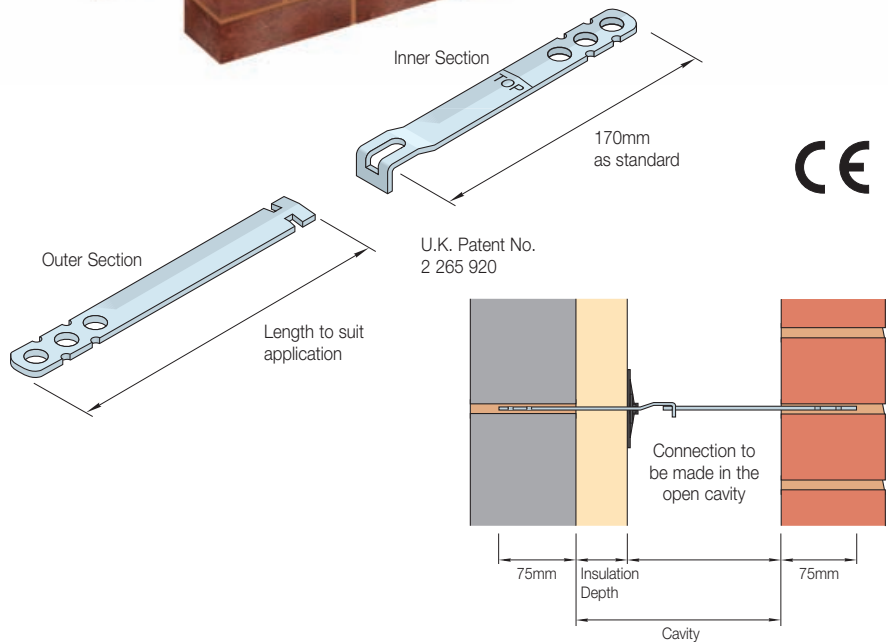
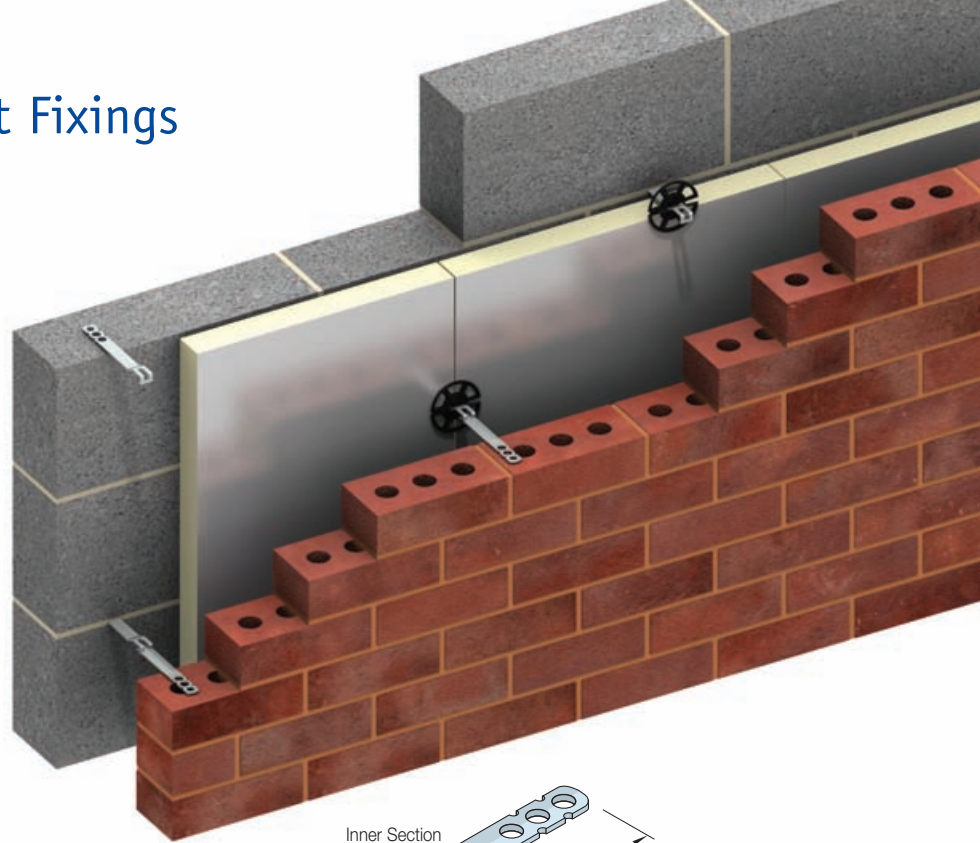

ANCON SLIP-BRICK TIES

Ancon Slip-Brick Ties are bolted directly to blockwork or concrete to give both support and restraint to thin slip brick facings.

In addition to the standard three brick version, slip brick ties can be manufactured in other multiples on request.

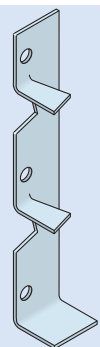

Ties for Steel Studwork

Ancon 25/14 Restraint System

The Ancon 25/14 system is designed to tie brickwork to steel studwork. Self-drilling screws fix through the channel and the rigid insulation board, into the steel. Once the channel is installed, Ancon SD25 wall ties can be positioned at any point along its length and are built into the bed joints of the outer leaf of brickwork.

The spacing of ties is based on the type and height of the building and its geographical location. Each tie has a performance in excess of Type 3 and the table below should be used in conjunction with the information on page 5.

Recommended Tie Spacing Based on 25/14 Channel at 600mm Horizontal Centres with Basic Wind Speed < 27m/s

Required Wall Tie Type	Vertical Centres (mm)
Type 1	225
Type 2	375
Type 3	450
Type 4	450

Note: Centres shown achieve equivalent tie type performances to PD 6697: 2010 6.2.2.5 Table 12. See page 5 for details.

Ancon recommends that wall ties achieve a minimum embedment of 62.5mm in the outer leaf of brickwork. Applications with a 50mm open cavity require 100mm long ties.

25/14 channel is available in lengths of 2700mm and 3000mm. It features pre-punched holes at close centres to ensure a fixing position is always located near the end, even when it is cut on site. It should be fixed to steel studwork at 450mm vertical centres.

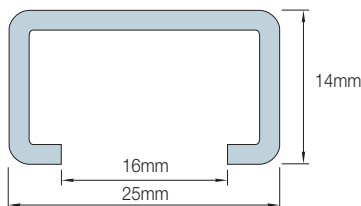

25/14 Channel Profile

Screws are available to accommodate a combined backing board and insulation thickness of up to 114mm and a steel thickness from 1.2mm to 3mm. Ancon recommends the use of stainless steel fixing screws.

The channel has a 16mm opening to easily accommodate a drive socket and washer for the fixing screws.

This system has been independently tested at CERAM Building Technology and meets the technical requirements of the NHBC.

Note: This system is unsuitable for use with flexible or semi-rigid insulations. Contact Ancon for further information.



Ancon 25/14 Channel with SD25 Wall Tie



Self-Drilling Screw Ref.	HTSS-65-2PT	HTSS-82-2PT	HTSS-100-2PT	HTSS-115-2PT	HTSS-135-2PT
Material	Stainless Steel	Stainless Steel	Stainless Steel	Stainless Steel	Stainless Steel
Diameter (mm)	5.5	5.5	5.5	5.5	5.5
Length (mm)	65	82	100	115	135
Insulation/Material Thickness (mm)	35-50mm	35-61mm	43-79mm	60-94mm	65-114mm

Wall Ties and Restraint Fixings

Ties for Thin-Joint Blockwork

Staifix-Thor Helical TJ2 Wall Tie

The TJ2 wall tie hammers directly into aerated concrete blocks, through insulation material, and is built into the bed joints of the outer leaf of brickwork. It is ideal for thin-joint blockwork and other applications where the joints in the inner and outer leaves are not aligned.

This tie meets the requirements of the NHBC and PD 6697 as a type 2 or 3 wall tie depending on the block used and the cavity width. The TJ2 has a cross-sectional area of 8.8mm².

The helix of the Staifix-Thor Helical range is superior to other helical fixings. Each rotation interlocks perfectly down its length guaranteeing maximum performance. Tools are available to simplify installation.

The black Staifix TJ Clip is designed for use with TJ2 wall ties.

Staifix HRT4 Wall Tie

For thin-joint to thin-joint separating walls use the Staifix HRT4 (see page 8).

Ties for Cellular Clay Blocks

Ancon has developed an innovative range of wall ties for use with cellular clay blockwork, where the horizontal bed joints are just 1mm.

The range includes cavity wall ties for use with external brickwork, cavity wall ties for internal separating walls to Approved Document E and ties for connecting perimeter walls to internal walls.

Installation of the component parts of cavity wall ties in this range are phased which eliminates any danger of injury from wall ties projecting from a part-built cavity wall.

Cellular Clay Block to Traditional Masonry

Cavity Width (mm)	Product Reference	Type 4 Performance	Type 3 Performance	Type 2 Performance
		Horizontal x Vertical Spacings (mm)		
100	CCB3-100	900 x 450	900 x 450	600 x 450
125	CCB3-125	900 x 450	900 x 450	600 x 450
150	CCB4-150	900 x 450	450 x 450	-

Notes: At vertical edges of an opening, unreturned or unbonded edges, additional ties should be used at a rate of one per 300mm height, located not more than 225mm from the edge. For complete information on tie types refer to PD6697: 2010. Tested to EN845-1:2003.

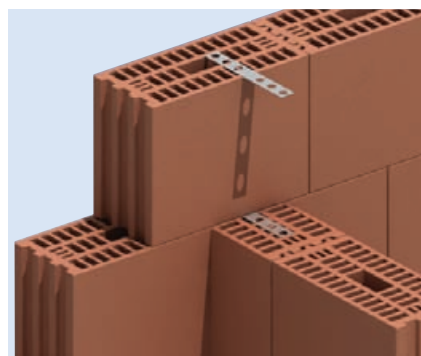

Ties for Internal Wall Junctions

TJ2 to PD 6697

Block Strength N/mm ²	Tie Type to PD 6697	
	50, 75, 100mm Cavity	125, 150mm Cavity
2.8 - 4.0	3	3
7.0 - 10.5	2	3

Note: For maximum building height and restrictions based on geographical location please refer to page 5.



Staifix-Thor Helical TJ2 Thin-Joint Tie
European Patent No. 1307303

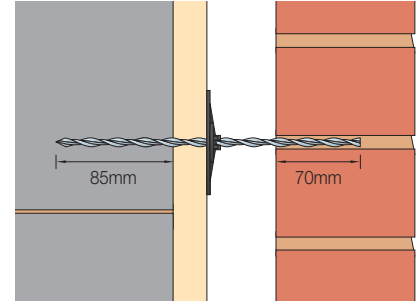
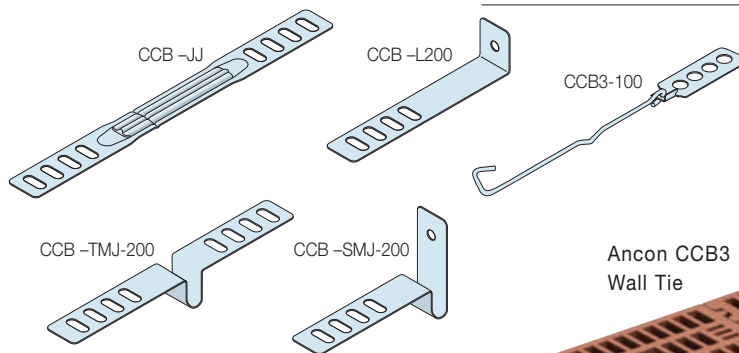

Embedment Depths

TJ2 Recommended Lengths

Cavity Width (mm)	Tie Length (mm)
50	205
75	230
100	255
125	280
150	305

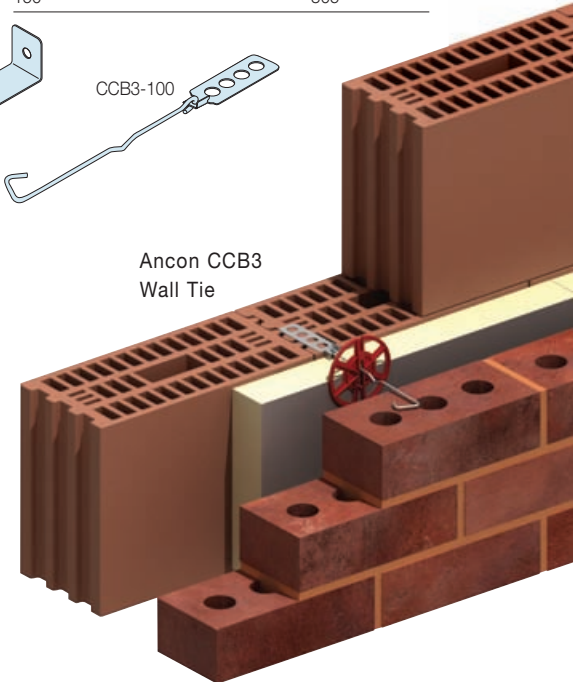

Ancon CCB3 Wall Tie

Cellular Clay Block to Cellular Clay Block for Internal Separating (Party) Walls

Cavity Width (mm)	Product Reference	Horizontal x Vertical Spacings (mm)
75	CCBA-75	900 x 450
100	CCBA-100	900 x 450

Note: Type A tie suitable for use in internal separating walls of any height to Approved Document E: Resistance to the Passage of Sound.

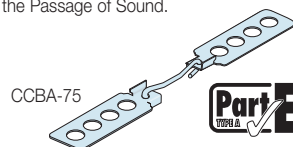

Flat Tie for connecting perimeter walls to internal walls

Product Reference	Length (mm)
CCB-IWJ-180	180

Note: For block widths greater than 140mm, two ties should be used per course.

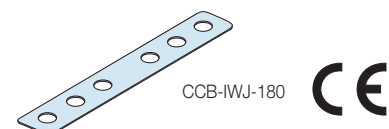

Ties for Bubble Foil Insulation

A range of ties are manufactured under license from Thermal Economics Ltd for use with Bubble Foil Insulation. These ties are available as Type 2 and Type 4 ties to PD 6697. ITB referenced ties enable the insulation material to be installed flush to the blockwork. ITC referenced ties position the insulation 25mm away from the block. These ties meet the technical requirements of the NHBC.

Wall Tie Reference	PD 6697 Type	Length (mm)	Cavity Range (mm)
TE-ITB4-185	4	185	50-60
TE-ITB4-200	4	200	60-75
TE-ITB4-225	4	225	85-100
TE-ITB4-250	4	250	110-125
TE-ITC4-200	4	200	60-75
TE-ITC4-225	4	225	85-100
TE-ITB2-185	2	185	50-60
TE-ITB2-200	2	200	60-75
TE-ITB2-225	2	225	85-100
TE-ITC2-200	2	200	60-75
TE-ITC2-225	2	225	85-100
TE-ITC2-250	2*	250	110-125

Notes: Refer to page 5 for more information on Type 4 and Type 2 ties. * Type 2 tie at 450mm vertical x 700mm horizontal centres.

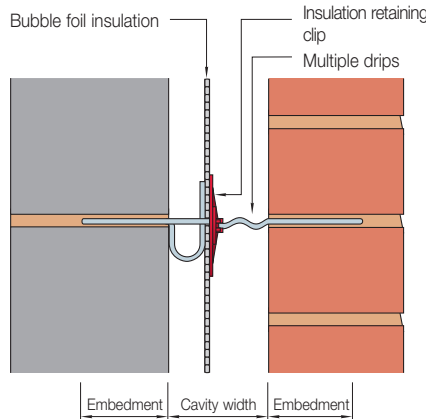

Installation of Staifix TE-ITC2 Wall Ties

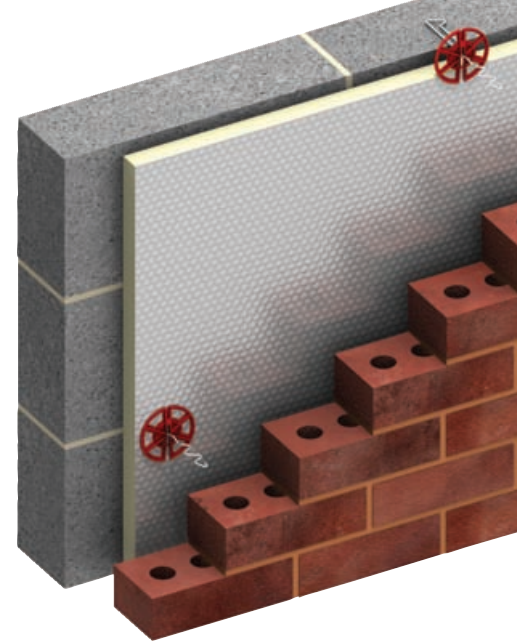
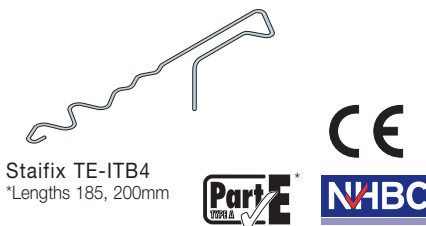

Staifix TE-ITB2 Wall Ties shown with Alreflex Ultratherm

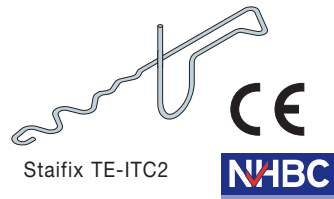

Ties for Timber Frames

Ancon manufactures two Type 6 Timber Frame Ties designed to fix brickwork or blockwork to timber-framed structures up to 4 storeys in height and accommodate maximum differential movement of 24mm.

Staifix Timber Frame Tie, STF6 (Type 6)

The Staifix STF6 tie is available in three lengths to suit 50mm, 75mm and 100mm cavities. It is supplied complete with an annular ring shank nail. The tie is cranked to simplify correct installation and to prevent moisture from crossing the cavity. The STF6 has a cross-sectional area of 12mm².

The Staifix STF6 tie has been independently tested for use with 15mm OSB (Oriented Strand Board) SIPS Panel. The standard annular ring shank nail should be replaced with a 4 x 30mm stainless steel Spax® screw.

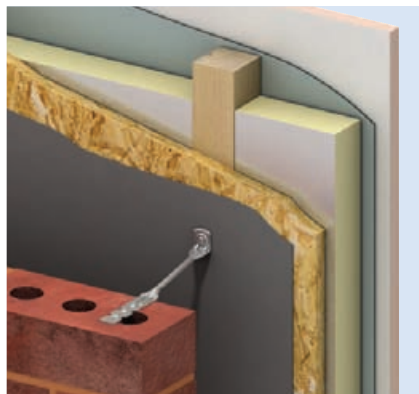

Staifix STF6 Timber Frame Tie
Available to suit 50mm, 75mm and 100mm cavities.



Staifix-Thor Helical Timber Tie, TIM6 (Type 6)

The Staifix-Thor Helical TIM6 is available in four standard lengths. It is suitable for cavities from 50mm to 150mm and can be used with the red Staifix Universal Clip where insulation has to be retained in the cavity. An installation tool is required to hammer the tie into the timber frame. The TIM6 has a cross-sectional area of 6.6mm².

TIM6 Recommended Lengths

Tie Length (mm)	Cavity Width (mm)	BS 5268 Type
175	50-60	5
175	61-75	6
200	76-100	6
225	101-125	6
250	126-150	6

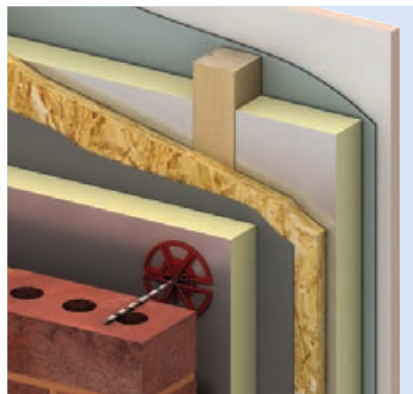

Staifix-Thor Helical TIM6 Tie



Ancon Timber Frame Movement Tie, TFMT7 (Type 7)

Where standard Type 6 Timber Frame Ties are unsuitable, Ancon recommends the use of the Timber Frame Movement Tie. Manufactured to suit any cavity from 50mm to 150mm, the Ancon Timber Frame Movement Tie comprises a channel, a strip tie and a screw. This system accommodates maximum differential movement of 65mm; the tie should be positioned 10-12mm from the bottom of the channel.

The TFMT7 complies with BS 5268-6.1 as a Type 7 tie. The product has a declared value of 960N. See page 5 for more information on Type 7 ties.

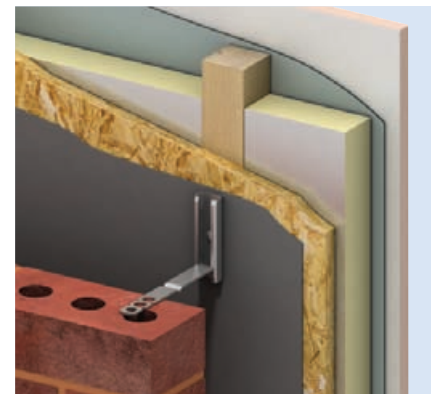

Ancon TFMT7 Timber Frame Movement Tie



Wall Ties and Restraint Fixings

Frame Cramps

Frame cramps are an ideal solution where a restraint is required between masonry and in-situ structures. They can be fixed to a range of materials including concrete, steelwork and masonry.

Ancon SDB Frame Cramps used as cavity wall ties exceed the requirements of a Type 2 tie to PD 6697 for cavities up to 300mm.

Recommended Tie Lengths and Fixing Centres for SDB Frame Cramps

Cavity Width (mm)	Length of Wall Tie (mm)	Recommended Spacing (mm)	
		Type 1	Type 2
20-44*	100	750 x 450	900 x 450
45-69	125	750 x 450	900 x 450
70-94	150	750 x 450	900 x 450
95-119	175	900 x 450	900 x 450
120-144	200	900 x 450	900 x 450
145-168	225	900 x 450	900 x 450
170-194	250	750 x 450	900 x 450
195-219	275	750 x 450	900 x 450
220-244	300	750 x 450	900 x 450

Note: *Due to limited length of tie a water drip would not be provided. Centres shown achieve equivalent tie type performances to PD 6697: 2010 6.2.2.5 Table 12. See page 5 for details.

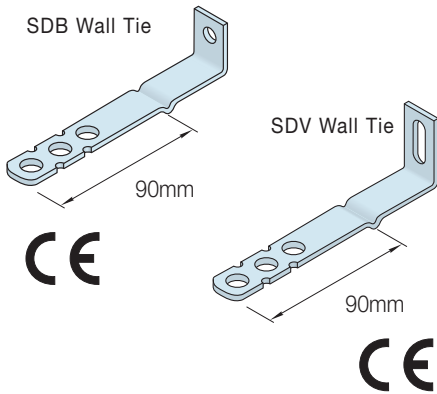

SDB Frame Cramps have a 7mm diameter hole to suit a range of fixings. Ancon M6 single expansion bolts are recommended for fixing to concrete and M6 set screws or SDTSS-38-5PT self-drilling screws for fixing to steelwork. Frame cramps can be fixed to masonry with suitable plugs and screws or resin anchors. Poor substrates will limit the capacity of fixings and site testing is advisable

in such applications. All fixings should be used in conjunction with a DIN washer.

Ancon SDV Frame Cramps have an 8mm x 30mm vertical slot that allows vertical fixing position adjustment where required. Their load capacity is limited when fixed in the top of the slot therefore they are not recommended for applications where tension is a consideration.

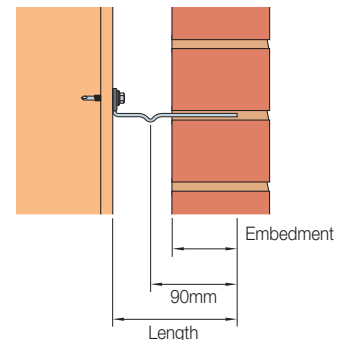
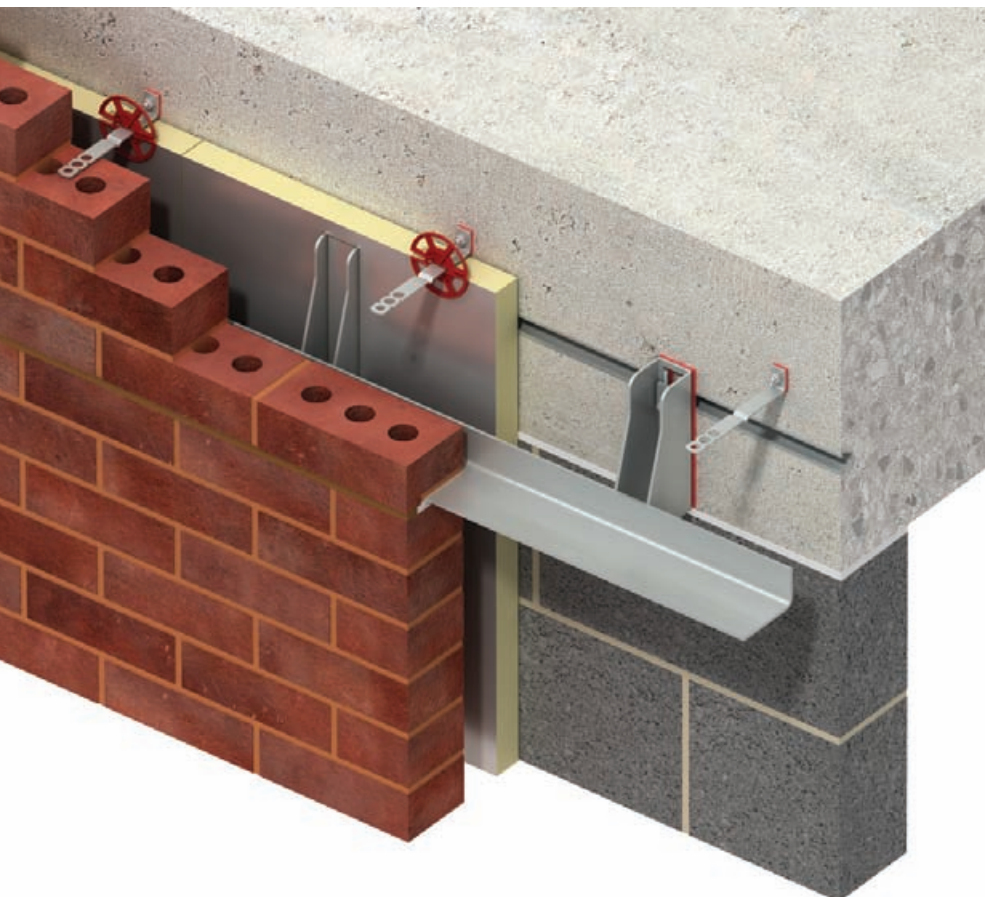

SDB Wall Tie Fixed to Steel with Self-Drilling Screw

Thermal Break

Ancon Frame Cramps can now be supplied with Thermal Breaks to be located between the upstand and the structural frame. They are manufactured from a durable fibre-reinforced thermoset plastic which has a thermal conductivity of just 0.3 W/mK.

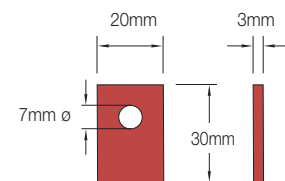

Frame Cramp Thermal Break

Isolation

Ancon isolation sleeves and pads are supplied blank for use with self-drilling screws to isolate stainless steel frame cramps from mild steel. Self-adhesive isolation pads are also available for __B (20 x 30mm) and __V (25 x 50mm) referenced frame cramps.

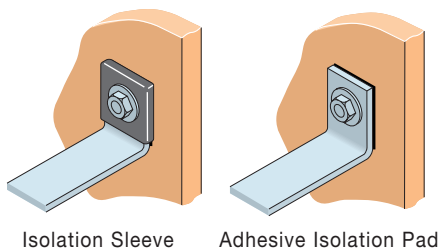

SPA Frame Cramp

Where masonry is in line with a column flange, frame cramps can be supplied with an offset angle section instead of an upstand. This angle allows the mechanical fixing to be suitably located. These ties are referenced SPA. They feature a 7mm hole as standard and can be used with a debonding sleeve if required at a movement joint. The thickness, size and shape of the angle section are designed to suit each application. Contact Ancon's Technical Department for more information.

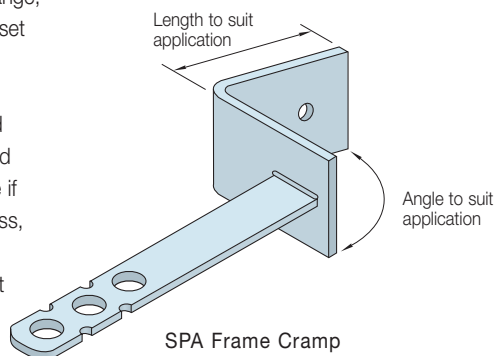

Ancon SPA frame cramp

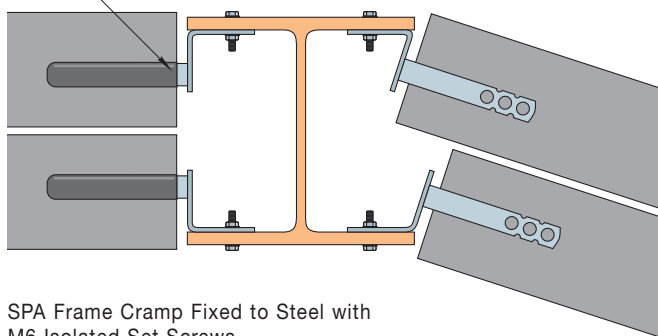

SPA Frame Cramp Fixed to Steel with M6 Isolated Set Screws

Ancon HiT - Hammer-in Tie

The Ancon HiT fixes masonry to concrete, dense blocks ($\geq 7N/mm^2$), non-perforated brick or hard stone. It can reduce the variety of tie lengths required on site and speed the rate of construction.

The HiT is available in a standard length of 310mm that is bent on site with a special installation tool to suit all cavities up to 150mm. Unlike conventional frame cramps it does not require a mechanical fixing, but is hammered into a plug.

The Ancon HiT meets the requirements of PD 6697 as a Type 2 tie. A neoprene 'O' ring must be installed on the tie to prevent moisture crossing the cavity.



Ancon Hammer-in Tie (310mm)

Pre-Fixing Aids

The practice of pre-fixing frame cramps in advance of masonry can accelerate the speed of construction and provides an opportunity to check that wall restraints have been located correctly and are securely fixed.

Ancon Gauge Tape (Pre-fix Patent 2 256 223)

Gauge Tape illustrates the standard 225mm brick/block gauge and the fixing position of frame cramps. It is applied directly to the structural frame (steel, concrete, timber or masonry) to facilitate the pre-fixing of frame cramps and to maintain accurate masonry coursing.

Ancon ISO-TW Washer

The ISO-TW washer enables Ancon slot-ended frame cramps to be vertically adjusted within the 30mm range of the slot to suit the exact location of mortar joints without affecting the integrity of the fixing. In addition, this washer prevents bi-metallic corrosion by separating the frame cramp from the structural frame and fixing screw.

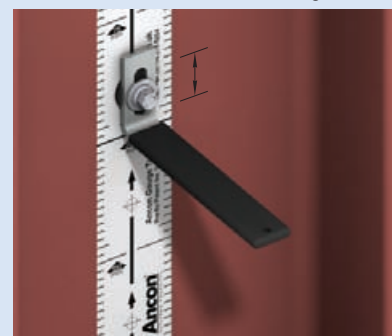

Ancon ISO-TW and Gauge Tape

Wall Ties and Restraint Fixings



Channel Ties

Ancon 21/18 Omega Channel

Ancon 21/18 Omega Channel is a high performance, self-anchoring, cast-in channel slot suitable for use with Ancon wall ties to provide the necessary restraint to the outer leaf of masonry. The section is only 18mm deep and can be used where there is reduced cover to reinforcement and concrete as thin as 75mm. Available in 100mm and 3000mm lengths, Ancon 21/18 Omega Channel is filled with polystyrene to help prevent the ingress of concrete. Nail holes aid the fixing of the slot to timber formwork.

Ancon 25/14, 28/15, 30/20, 38/17, 36/8 and 40/25 Channels

Ancon wall ties can also be used with our 25/14, 28/15, 30/20, 38/17, 36/8 and 40/25 channels.

30/20 Channel is supplied with anchors for casting into concrete. 25/14 and 36/8 Channels are supplied plain-backed for surface fixing. 28/15, 38/17 and 40/25 Channels are available with or without anchors for casting in or surface fixing. Data shown below applies to cavity wall ties into 21/18, 28/15, 30/20, 38/17 and 40/25 cast-in channels. 36/8 channels are only suitable for shear applications, see page 17. For 25/14 channels see pages 11.

Maximum safe working loads of surface-fixed channels will be subject to suitable fixings, and appropriate fixing centres. Consult Ancon's Technical Department for advice.

Available Lengths of Ancon 21/18 Omega Channel
100, 3000mm
 U.K Patent No. 2 249 110

Ancon 21/18 Omega Channel with Ancon SD21 Tie

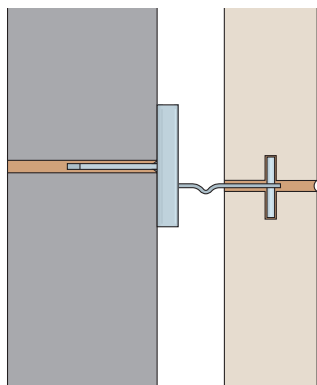

Fastrack used with DD28 Tie for Stonework

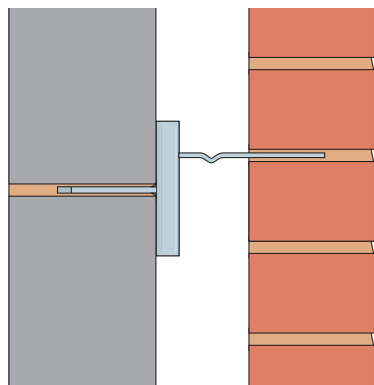

Fastrack used with SD28 Tie for Brickwork



Recommended Fixing Centres for Cast-in Channel Ties for Masonry Cavity Applications

Tie Length (mm)	Cavity Width (mm)	Type 1	Type 2
125	45-69	450x450	900x450
150	70-94	450x450	900x450
175	95-119	600x450	900x450
200	120-144	600x450	900x450
225	145-169	600x450	900x450
250	170-194	600x450	900x450
275	195-219	600x450	900x450
300	220-244	600x450	900x450

Note: Centres shown achieve equivalent tie type performances to PD 6697: 2010 6.2.2.5 Table 12. See page 5 for details.

Fixing of Channel

Fixing Method	Omega 21/18	25/14	28/15	30/20	38/17	36/8	40/25
Cast-in	✓	✗	✓	✓	✓	✗	✓
Surface Fixed	✗	✓	✓	✗	✓	✓	✓

Ancon Fastrack

Building one leaf of the cavity wall in advance of the other is often beneficial but can create problems with coursing. Buildings which incorporate imperial or continental bricks and standard metric blocks present even greater difficulties.

Ancon Fastrack Channel is built into the inner leaf of blockwork ready to take an Ancon SD28 or similar tie for the outer leaf. This method of construction avoids the dangers of projecting ties.

Ancon Fastrack Channels and Ties suit cavities from 50mm to 150mm and can also be used for tying stonework to blockwork if DD28 or similar Ancon Ties are used.

The recommended tie length for use with a fastrack channel is 'cavity width plus 50mm'.



Ancon Fastrack Channels 100mm long with SD28 Tie

Ancon 28/15 Fastrack Channels and Ties sustain loads which exceed the requirements for a Type 2 tie to PD 6697. This system can also be manufactured in a 36/8 channel which has a Type 3 performance and that accepts wall ties referenced __ 36.

Tie Reference	Type 1	Type 2	Type 3	Type 4
28/15 Fastrack	450x450	900x450	900x450	900x450
36/8 Fastrack	450x450	600x450	900x450	900x450

Note: Centres shown achieve equivalent tie type performances to PD 6697: 2010 6.2.2.5 Table 12. See page 5 for details.

Vertical Movement Joints

Debonding sleeves are used on plain-ended wall ties, such as the Ancon PP21 or PPB, at vertical movement joints that abut columns. The tie will restrain the masonry against lateral wind loads whilst the sleeve allows the masonry to expand and contract.

These shear ties are available either to suit cast-in channels or as frame cramps to be post-fixed on site. Channel ties are available to suit Ancon 21/18, 28/15, 30/20, 36/8, 38/17 and 40/25 channels. Frame cramps are available as a PPB with a single hole or as a PPV with a vertical slot. PPS ties are used across movement joints in masonry walls. PPB-HD is a heavy duty version of the PPB.

Design Resistances for Shear Ties

Tie	Design Resistance (N)	Design Resistance per metre (N/m)	
		450mm centres	225mm centres
Channel Ties	900	2000	4000
PPV	463	1028	2056
PPB	630	1400	2800
PPB-HD	896	1991	3982
PPS	866	1924	3848

Note: Design resistances shown use a material factor, γ_m of 3.0 as given in the UK National Annex to BS EN 1996-1-1:2005

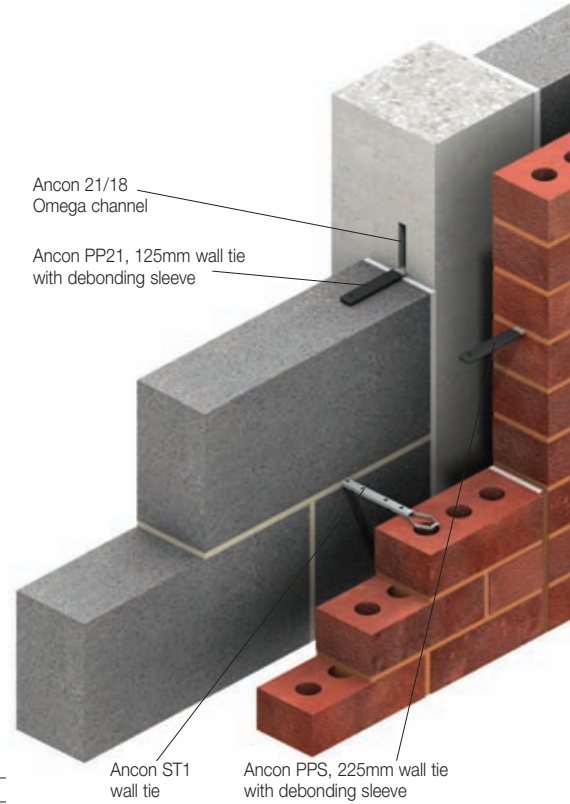

Intermediate Column with Vertical Movement Joint in Brickwork and Blockwork

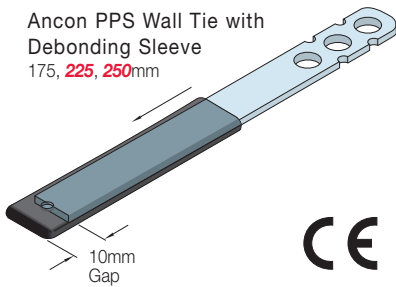

Debonding sleeves should be pulled back 10mm to allow expansion as well as contraction of brickwork

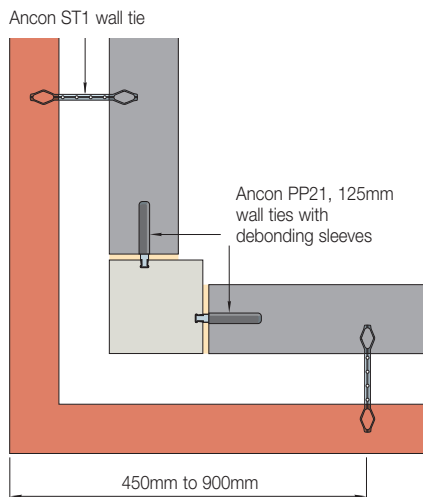
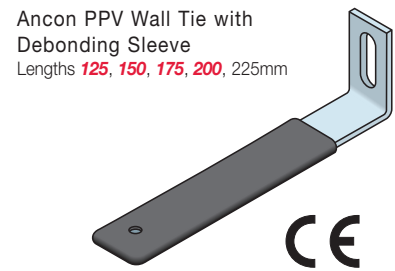
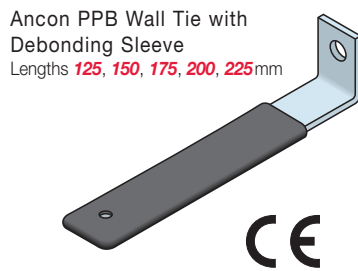

External Corner with Fully Bonded Brickwork

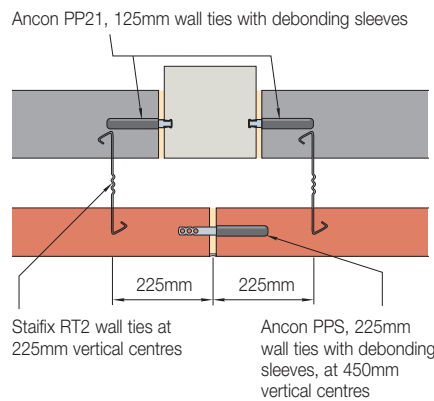

Intermediate Column with Vertical Movement Joints in both Brickwork and Blockwork

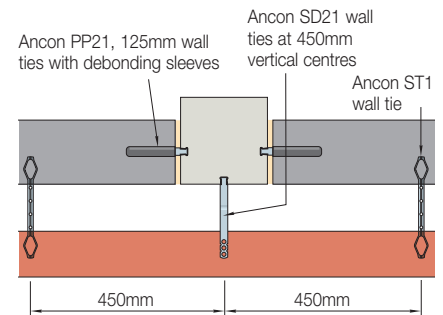

Intermediate Column with Vertical Movement Joints in Blockwork

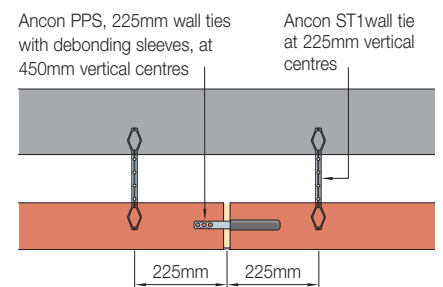

Cavity Wall with Vertical Movement Joint in Brickwork

Note: All spacings are maximums. The type of cavity wall tie and spacing will be determined by the cavity width, height of brickwork, wind loading and type of building. See page 5 for further information.

Wall Ties and Restraint Fixings

Standard Wall Ties

Lengths shown in **red italics** refer to items normally available at all times. Reasonable quantities can be delivered within 24 hours of acceptance of an order.

Ancon and Staifix wall ties are also available from builders merchants and other specialist distributors. For further information regarding the availability of any fixings or details of your nearest stockist, please contact Ancon sales staff.

Ancon's Technical Services Team will be pleased to advise on the correct selection and use of our wall ties.

ST1

Lengths **200, 225, 250, 275, 300**mm
Conforms to PD 6697 as a Type 1 tie
U.K. Patent Nos. 2 255 358,
2 260 348 & 2 260 349

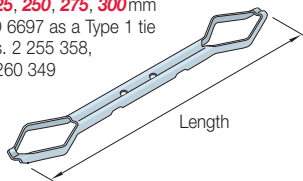

Teplo1

Lengths **200, 225, 250, 275**mm
Conforms to PD 6697 as a Type 1 tie.
Due to testing completed to date the use of Type 1 TeploTies is restricted to buildings up to 18m in height.



SD1

Lengths **200, 225, 250, 275, 300**mm
Conforms to PD 6697 as a Type 1 tie
Also available with a central drip

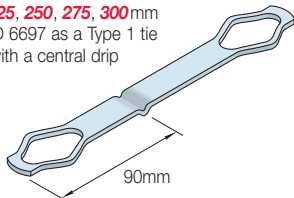

RT2

Lengths **200, 225, 250, 275**mm
Conforms to PD 6697 as a Type 2 tie
Patent Nos. GB 2359831
IE 83574

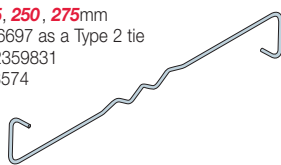

Teplo2

Lengths **200, 225, 250, 275, 300, 325, 350, 375, 400, 425**mm
Conforms to PD 6697 as a Type 2 tie



Recommended Lengths for Masonry/Masonry Wall Ties

Cavity Width (mm)	Tie Length (mm)
50-75	200
76-100	225
101-125	250
126-150	275
151-175	300
176-200	325
201-225	350
226-250	375
251-275	400
276-300	425

HRT4

Lengths **200, 225, 250, 275**mm
Conforms to PD 6697 as a Type 4 tie
Patent Nos. GB 2359831
IE 83574

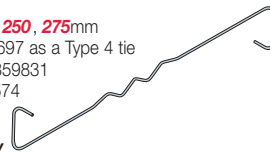

Suitable for party walls with 50-100mm and 125-150mm cavities



Teplo4

Lengths **200, 225, 250**mm
Conforms to PD 6697 as a Type 4 tie



DT (Double Triangle)

Lengths **150****, **200***, **225***, **250****, **300****mm
*Conforms to EN 845-1 and PD 6697 as a Type 2 tie
**Conforms to EN 845-1 and PD 6697 as a Type 3 tie



SPB

Lengths 75, **100, 125, 150, 175, 200**mm
(Heavy duty version also available)

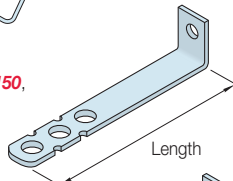

SDB

Lengths **125, 150, 175, 200, 225**mm

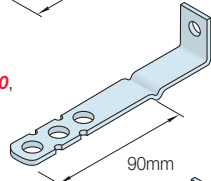

PPB

Lengths **125, 150, 175, 200, 225**mm

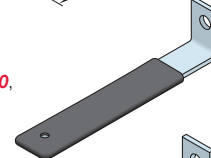

SPV

Lengths 75, **100, 125, 150, 175, 200**mm.

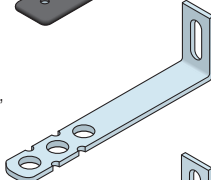

SDV

Lengths **125, 150, 175, 200, 225**mm

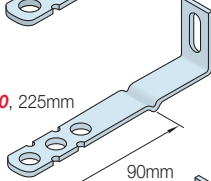

PPV

Lengths **125, 150, 175, 200, 225**mm

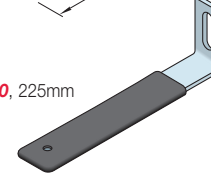

Recommended Lengths for Frame Cramps and Cast-in Channel Ties*

Cavity Width (mm)	Tie Length (mm)
<20	75
20-44	100
45-69	125
70-94	150
95-119	175
120-144	200
145-169	225

*Excluding surface-fixed channels and Ancon Fastrack

SP21

Lengths **75, 100, 125, 150, 175, 200**mm
For use with 21/18 Omega Channel

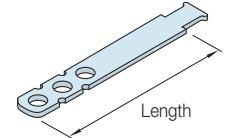

SD21

Lengths **125, 150, 175, 200, 225**mm
For use with 21/18 Omega Channel

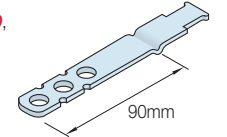

PP21

Lengths **125, 150, 175, 200, 225**mm
For use with 21/18 Omega Channel

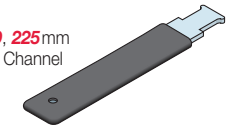

SPS

Lengths **150, 200, 225, 250, 275, 300**mm
(Not suitable for collar-jointed construction. See below)

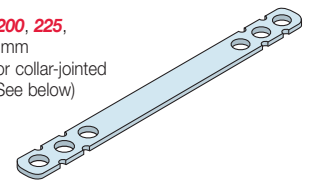

SPS CJ

Length **150**mm
(3mm thickness for collar-jointed construction)

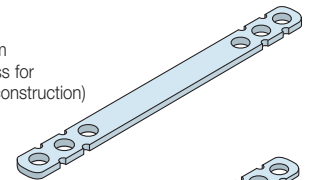

PPS

Lengths 175, **225, 250**mm

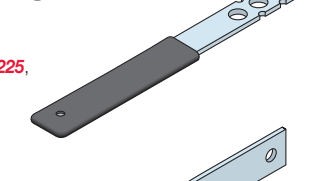

SHX

Lengths 150, 175, 200, 225mm

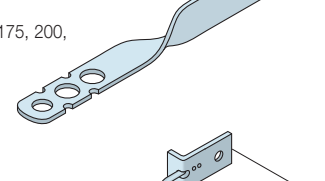

WHX

Lengths 150, 175, 200mm

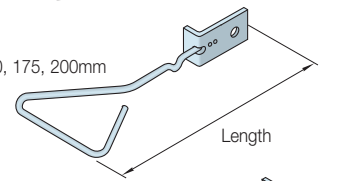

SRB

Lengths **125, 150, 175, 200**mm
(Used in applications instead of the SDB where greater flexibility is required)

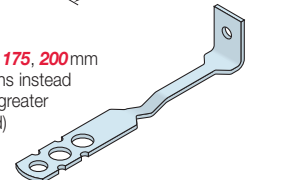

Cavity Starter Tie

Supplied with an 8mm nylon wall plug and neoprene ring
Lengths **180, 200, 230**mm

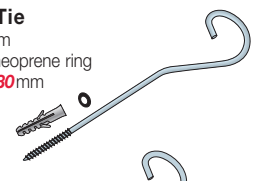

Starter Tie

Supplied with an 8mm nylon wall plug
Length **135**mm

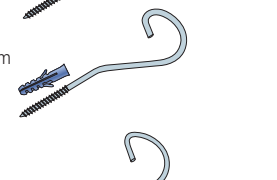

Frame Tie

Length **130**mm



References for Wall Ties

Many variations are available in addition to the standard ties. Wall ties for special applications may be specified and ordered with ease by using a reference letter for the tail, shank and head of the tie.

These bespoke ties are manufactured to order, typically for use on a single unique project and therefore are not tested to EN 845 and do not carry CE marking.

Ancon ties are produced in lengths from 150mm for masonry-to-masonry ties, and 75mm for masonry-to-concrete ties, in increments of 25mm. Drips will usually be positioned 90mm from the outer end of the tie (first reference letter). Masonry-to-masonry ties can also be supplied with a central drip. Special wall ties with a section wider than 20mm referenced S_ _ , will have an end with three holes without the side notches.

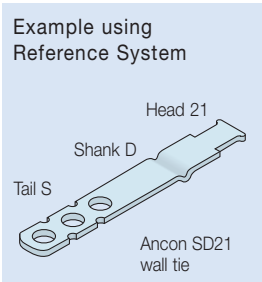
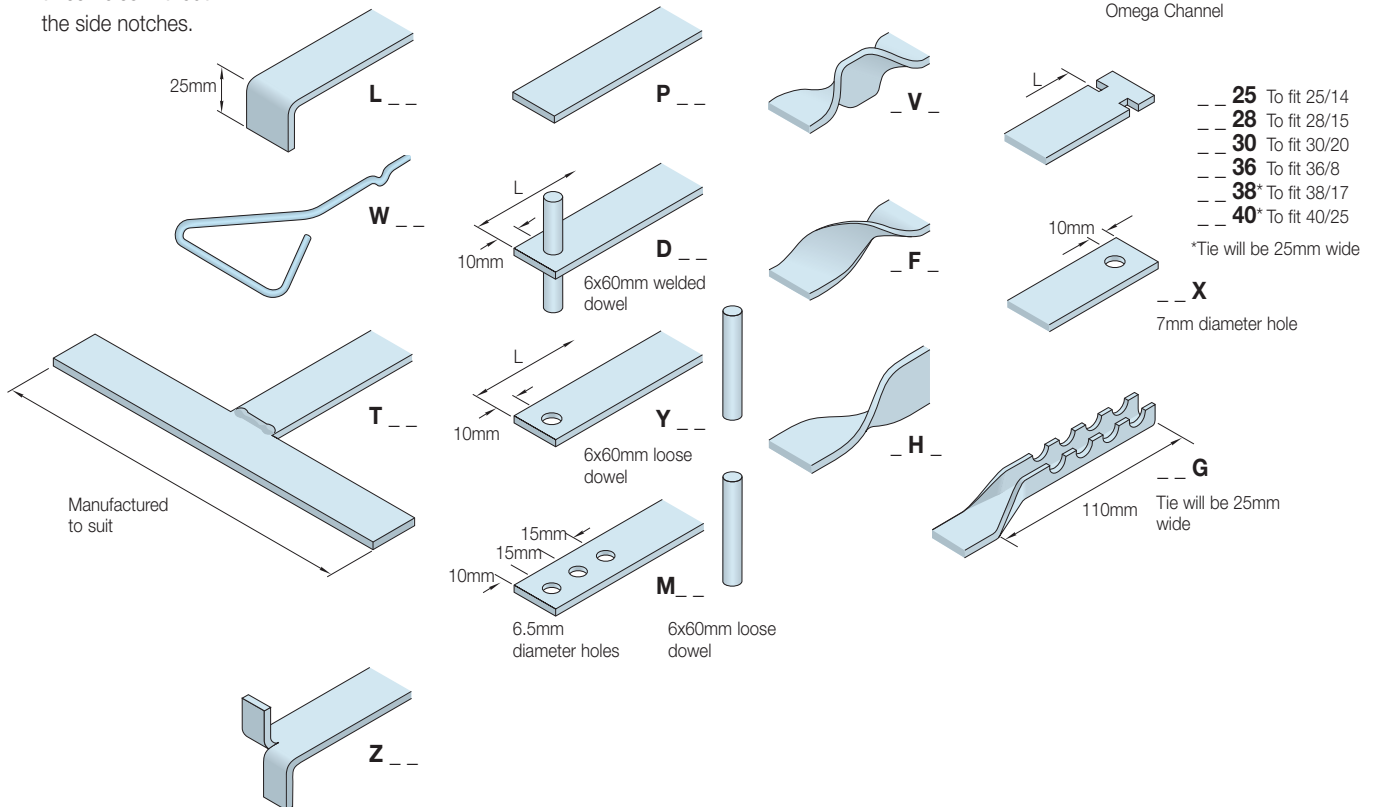

Insulation Retaining Clips

The red Staifix Universal Insulation Retaining Clip (Uni) will fit all the standard stainless steel ties shown on page 18. The black Teplo-Clip should be used with the TeploTie range. The black TJ Clip is suitable for Ancon Two-Part Ties and the TJ2 wall tie (see page 12).

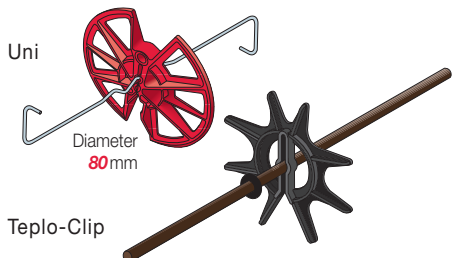

Insulation Retainer

The H75/2 Insulation Retainer is for securing masonry to concrete, blockwork and brickwork. The 90mm diameter head can hold back up to 75mm of insulation. A 10mm diameter hole is required in the base material. The projecting end of the retainer is pushed through the insulation material into the hole and tapped into position to secure the insulation.

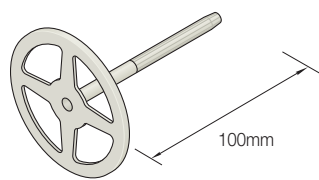

Debonding Sleeves

Debonded Ties require 100mm embedment. A 120mm long sleeve will provide an allowance for movement and tolerance, and will be suitable for most applications. Other lengths and sizes available to special order.

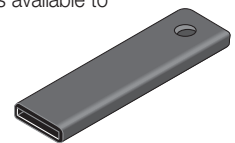

Wall Ties and Restraint Fixings

Non-Drill Fixings for Steelwork

Ancon's range of 'NON-DRILL' masonry-to-steel fixing solutions was developed to address the safety concerns of the Industry.

Driven by customer demand for masonry restraint fixings with an alternate installation method from either shot-firing or drilling, Ancon engineered the innovative solutions detailed here. These fixings do not require the use of power tools and can reduce installation times and costs. In all instances they simply about the column or attach to the flange to restrain the wall against lateral wind loads.

Design Sheets

Contact Ancon on +44 (0) 114 275 5224 or visit www.ancon.co.uk for a Non-Drill Fixings Design Sheet. This sheet summarises all the information required by Ancon to specify/quote for the most appropriate non-drill fixing to suit your application.

Ancon NON-DRILL fixings:

- Eliminate the dangers associated with shot-firing and drilling
- Quick, simple and economical to install
- No power tools required
- No special skills or equipment required
- Fixings either about the column or attach to the flange

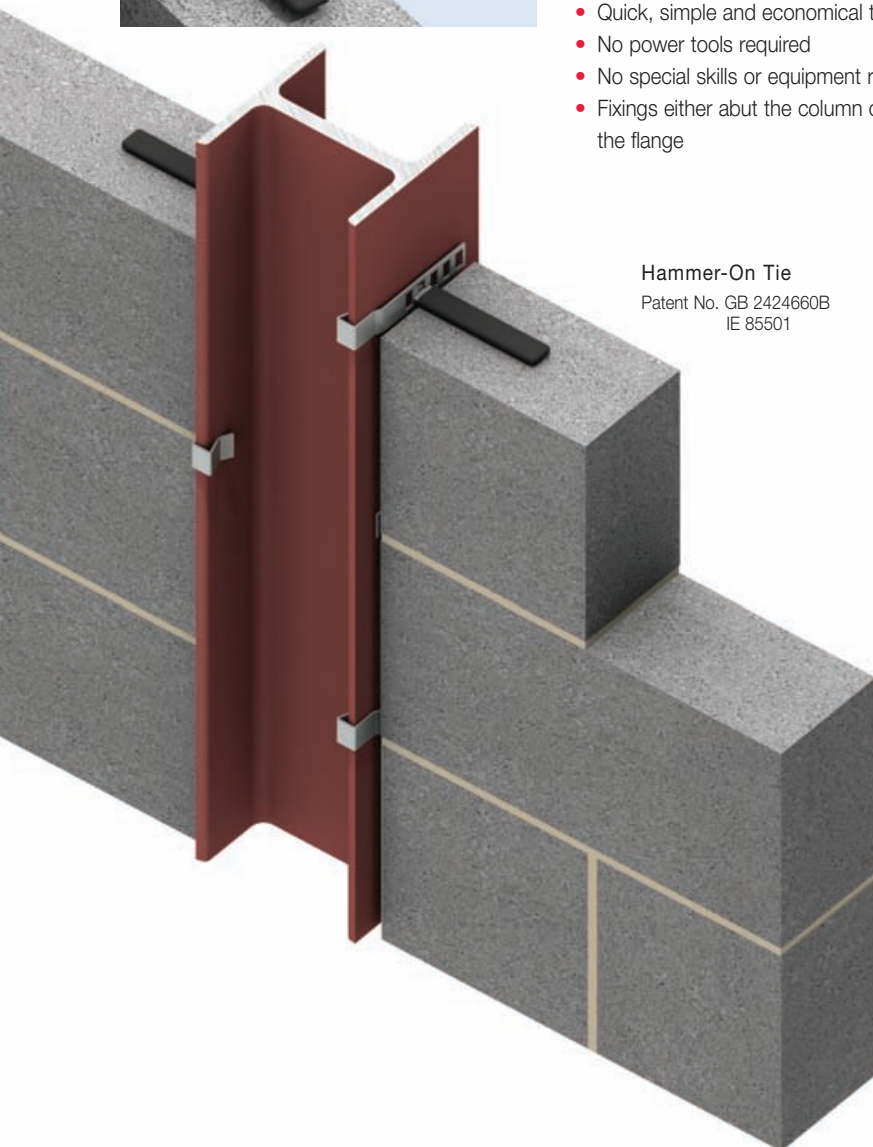
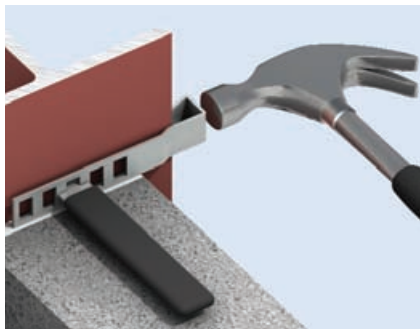

Hammer-On Tie
Patent No. GB 2424660B
IE 85501

Hammer-On Section

Available in five sizes to accommodate a steel thickness from 7mm to 25mm, this fixing is simply hammered onto the flange. It can be utilised either on a column with a tie (HOS-TIE) or on a beam with an internal head restraint (IHR-H).

Hammer-On Section Size	Flange Thickness Accommodated
XS	7-10mm
S	10-13mm
M	14-17mm
L	18-21mm
XL	22-25mm

The wall tie (HOS-TIE) or head restraint (IHR-H) should be positioned central to the masonry leaf when located in one of the five fixing slots. The Hammer-On section is available in three lengths. Hammer-On Ties should be installed at 225mm vertical centres and Hammer-On Head Restraints at 450mm horizontal centres. For more information on the IHR-H Head Restraint see page 22.

The Hammer-On Section resists load in one direction only and should be installed on alternate sides of the flange.

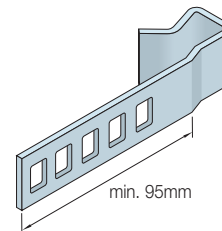

Hammer-On Section
Lengths 95mm, 155mm, 215mm

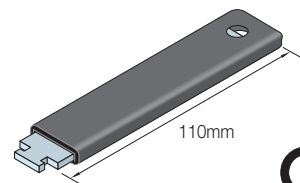

Hammer-On Tie (Debonded HOS-TIE, pictured above, supplied complete with Hammer-On Section)

Hammer-On Ties used at 225mm centres provide a design resistance of 1925N per metre.

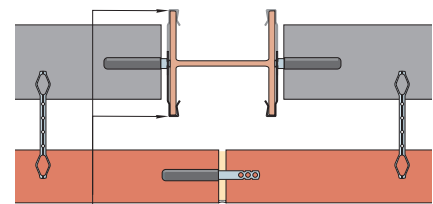

Hammer-On Ties installed to alternate sides of the column at 225mm vertical centres

Internal Column Tie

Available in seven lengths, this tie fits between the flanges of a column. It should be installed at 225mm vertical centres, providing a design resistance of 6355N per metre.

Length (mm)	Beam/Column Accommodated
179	203 x 203 UC
186	203 x 133 UB
224	254 x 254 UC
232	254 x 146 UB
275	305 x 305 UC
281	305 x 127 & 165 UB
330	356 x 127 & 171 UB

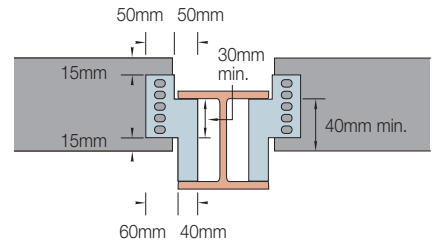
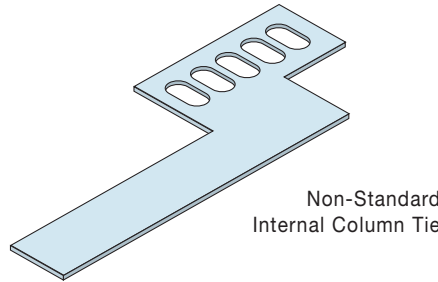
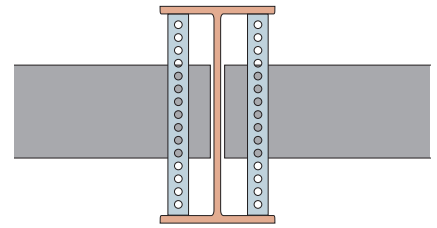
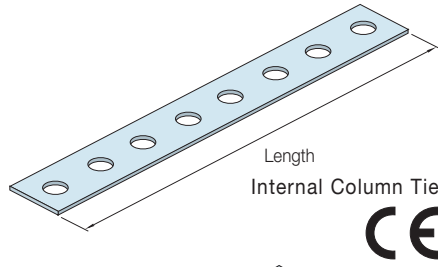

Non-Standard Internal Column Tie

Special internal column ties can be designed to suit applications where the masonry does not sit inside the flanges of a column. The drawing provides some guidance on dimensions; contact Ancon for more information.

New Briclok

The Briclok fits to a column flange and can be used either across a cavity or back into the inner leaf. It should be positioned with the appropriate notch around the flange and installed at 225mm vertical centres. The tie must not be forced onto the column and should have no less than 10mm engagement. Two types (A and B) accommodate a steel thickness from 6.8mm to 20mm and are available in two lengths to suit an open cavity from 20mm to 80mm.

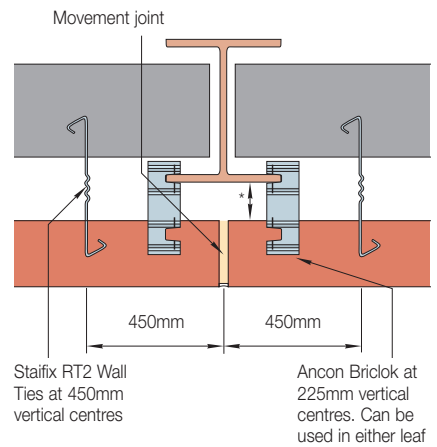
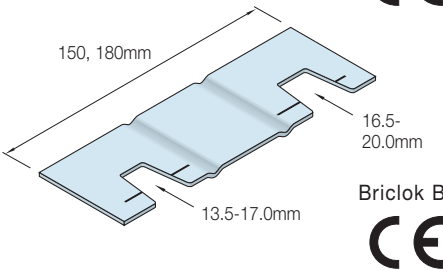
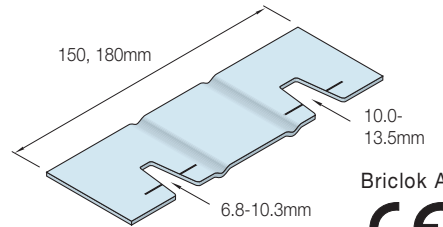

Briclok ties exceed the requirements for a Type 1 tie to PD 6697 in type M2 (iv) mortar.

Column Tie

The Column Tie clamps to the flange of a column. It accommodates a steel thickness from 6mm to 25mm and should be installed at 225mm vertical centres. Manufactured in lengths to suit the application, it can feature a drip for use across the cavity or a plain shank for installation back into the inner leaf.

Product Code	Length	Open Cavity*	Flange Thickness
Briclok150A	150mm	20-50mm	6.8-13.5mm
Briclok180A	180mm	50-80mm	6.8-13.5mm
Briclok150B	150mm	20-50mm	13.5-20.0mm
Briclok180B	180mm	50-80mm	13.5-20.0mm

* Open cavity at column face.

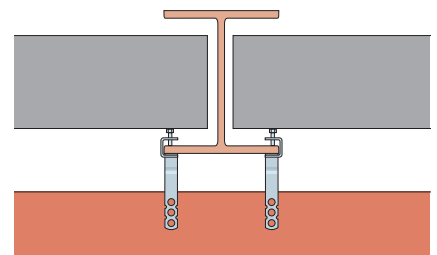
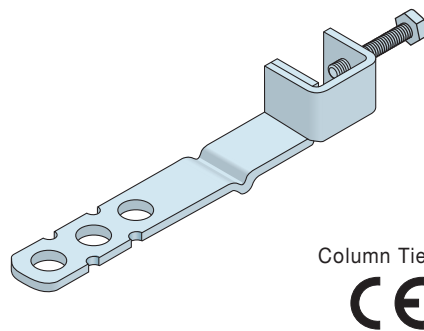

Avoiding Bi-Metallic Corrosion

Bi-metallic corrosion may occur in a damp environment where stainless steel fixings are in contact with a structural steel frame. This will not affect the stainless steel but may cause slight surface corrosion to the mild steel. Best practice is to isolate the two dissimilar metals. Bitumen paint or some other form of isolation e.g. adhesive tape, applied at the point of contact will prevent this corrosion.

Wall Ties and Restraint Fixings

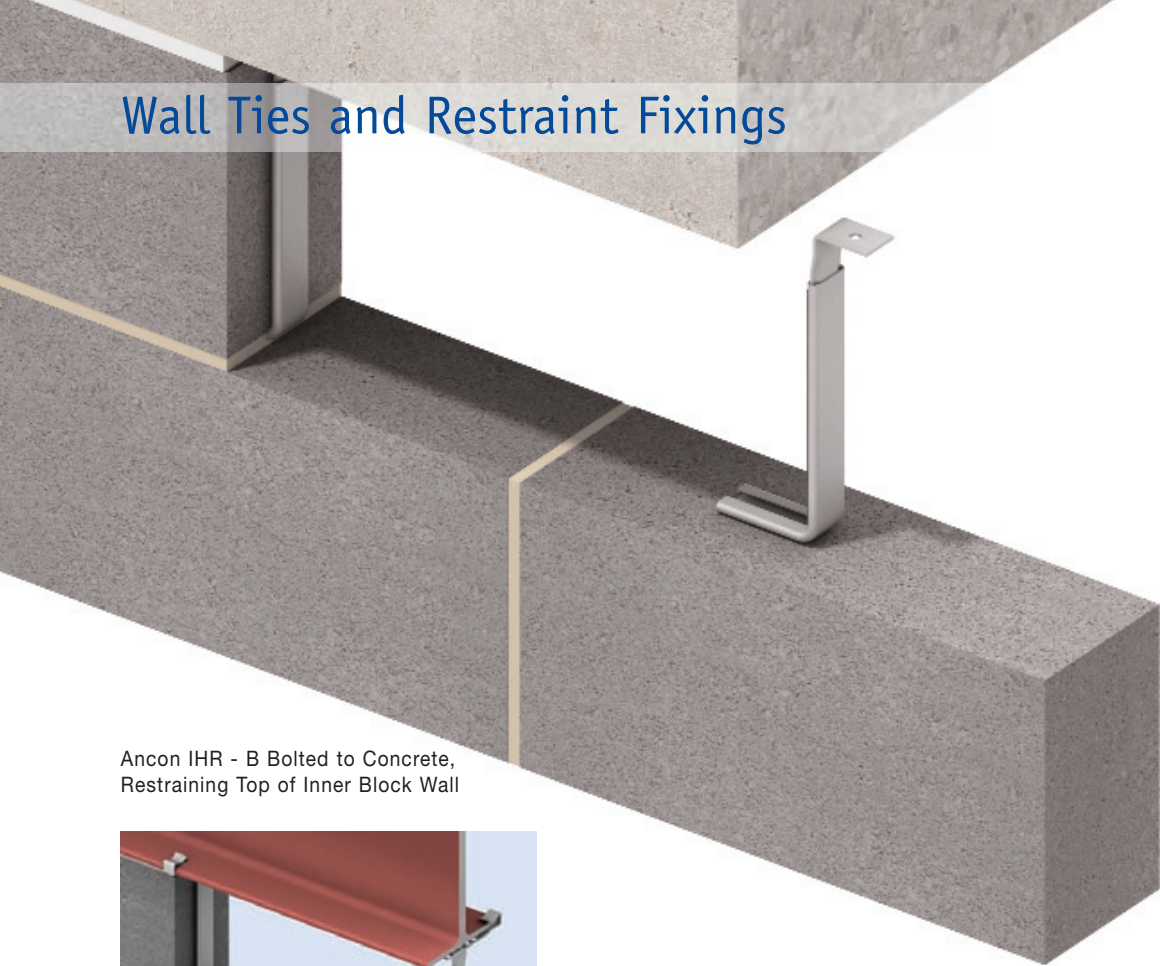

Ancon IHR - B Bolted to Concrete, Restraining Top of Inner Block Wall

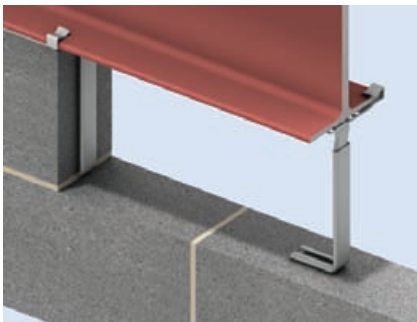
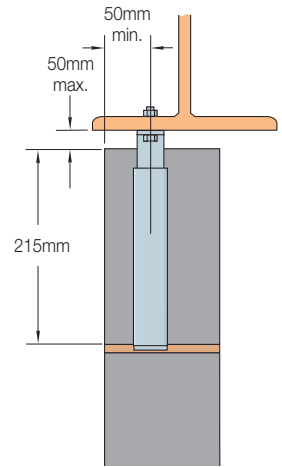

Ancon IHR-H Hammer-On Head Restraint

Ancon Head Restraints

Ancon Head Restraints provide the necessary restraint to the top of masonry walls. They allow for vertical movement to accommodate shrinkage or thermal movement of the wall or structural frame, while restraining wind loads.

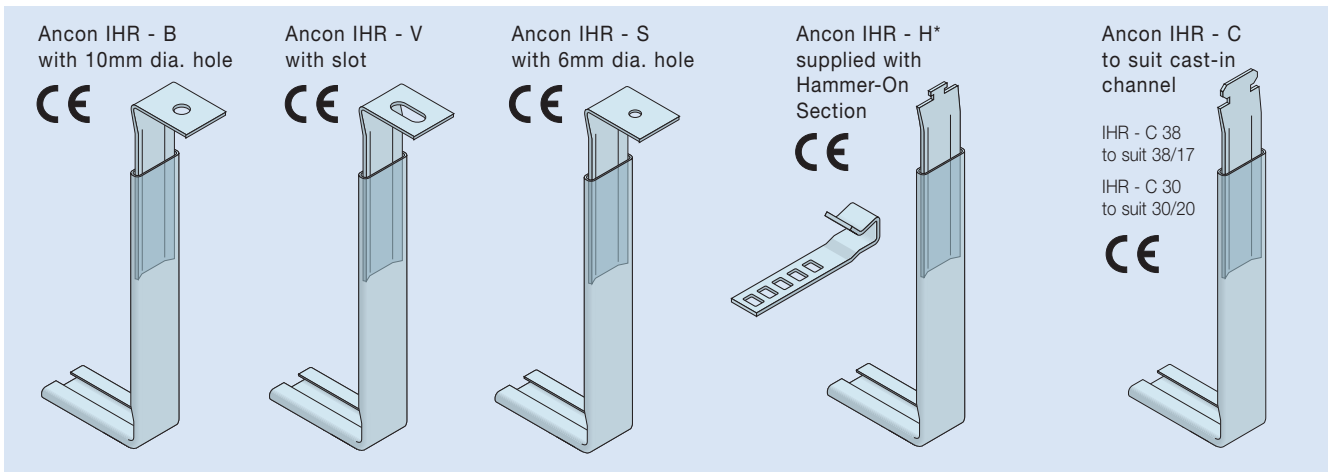

Ancon IHR - Internal Head Restraint

The Ancon IHR is used for restraining the top of internal walls or the top of the inner leaf of a cavity wall. The opening at the front of the channel stem is sealed to prevent mortar ingress and to ensure that vertical movement can take place between the blockwork and the structure. The base of the stem must be built within a bed joint with the centre of the stem no closer than 50mm from the edge of the block. The vertical joint should be filled with mortar each side of the stem. The maximum joint between the top of the blockwork and the

underside of the frame is not normally greater than 50mm. When used at 900mm centres the IHR provides a design resistance of 1714N/m and at 450mm centres provides a design resistance of 3429N/m. The standard IHR will suit a 215mm block; other sizes between 150 - 250mm are available.

*The IHR-H, when fixed at 450mm centres staggered each side of the lower beam flange (effective centres 900mm on each side), has a design resistance of 1133N/m per metre in either direction.

The sliding tie can be provided with either a hole (IHR - B) or slot (IHR - V) to suit M8 bolts, with a notch end to fix directly into a 38/17 or 30/20 cast-in channel (IHR - C) and with a notch end to suit the Hammer-On Section (page 20) that attaches to a 4mm - 12mm steel flange without site drilling (IHR - H). It is also available to suit the SDTSS-38-5PT self-tapping screw (IHR-S).

Ancon FHR - Head Restraint

The Ancon FHR Head Restraint is used for restraining the top of internal walls or the internal leaf of a cavity wall. The two angles clamp the top of the wall and have 10mm diameter holes to suit M8 bolts. They are supplied with two holes in the longer angle to allow the restraint to fit 100mm and 140mm blockwork. Each restraint provides a design resistance of 1890N.

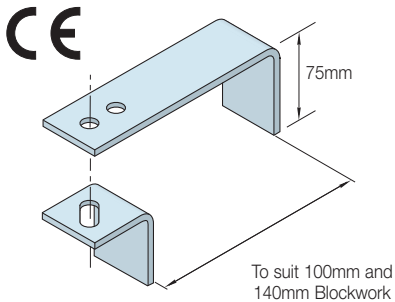

Ancon FHR Head Restraint - other sizes available

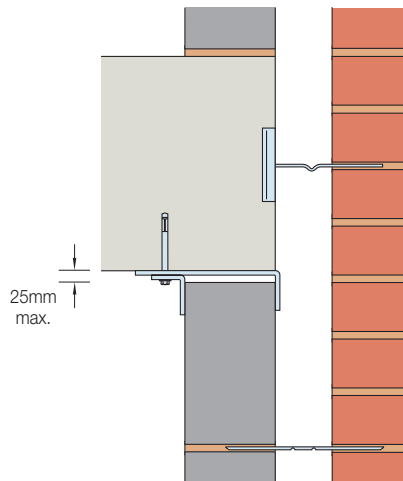

Ancon FHR Head Restraint Fixed to Underside of Floor Slab, Restraining Head of Inner Leaf of Cavity Wall

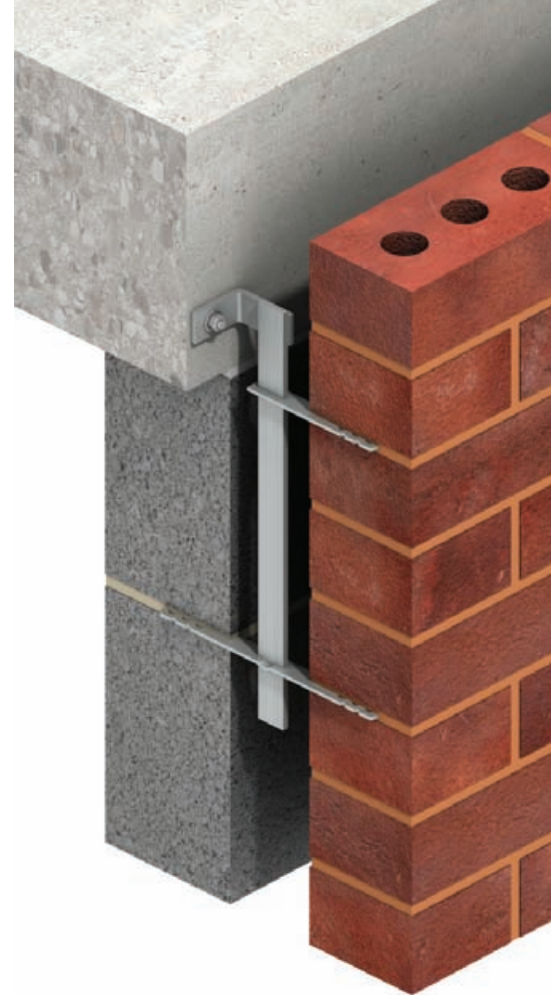

Ancon SAH - Sliding Anchors

Ancon SAH Sliding Anchors have stems which fit within the cavity and accept ties that slide to accommodate vertical movement. Available with five different head options as standard, they can be supplied with one-way or two-way ties with safety ends.

The standard fixing hole is 12mm diameter to suit Ancon M10 Single Expansion Bolts or M10 T-Head Bolts to fit Ancon 28/15 Channel. Ancon SAH Sliding Anchors have a design resistance of 755N per stem when the upper tie is within 75mm of the fixing. Ties should be spaced at a minimum of 150mm and at least two ties should be used per stem.

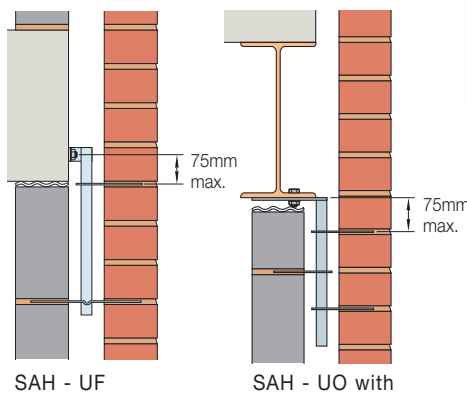

SAH - UF

SAH - UO with Extended Head

These drawings are examples only. All sliding anchors are manufactured to suit individual requirements.

SIS
Standard Lengths
200, 230mm

Slot is positioned at the centre of the tie

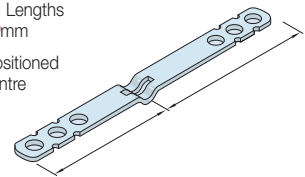

Other lengths and slot positions available to suit application

SPI
Standard Lengths
135, 150mm

Other lengths available to suit application

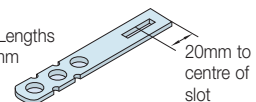

20mm to centre of slot

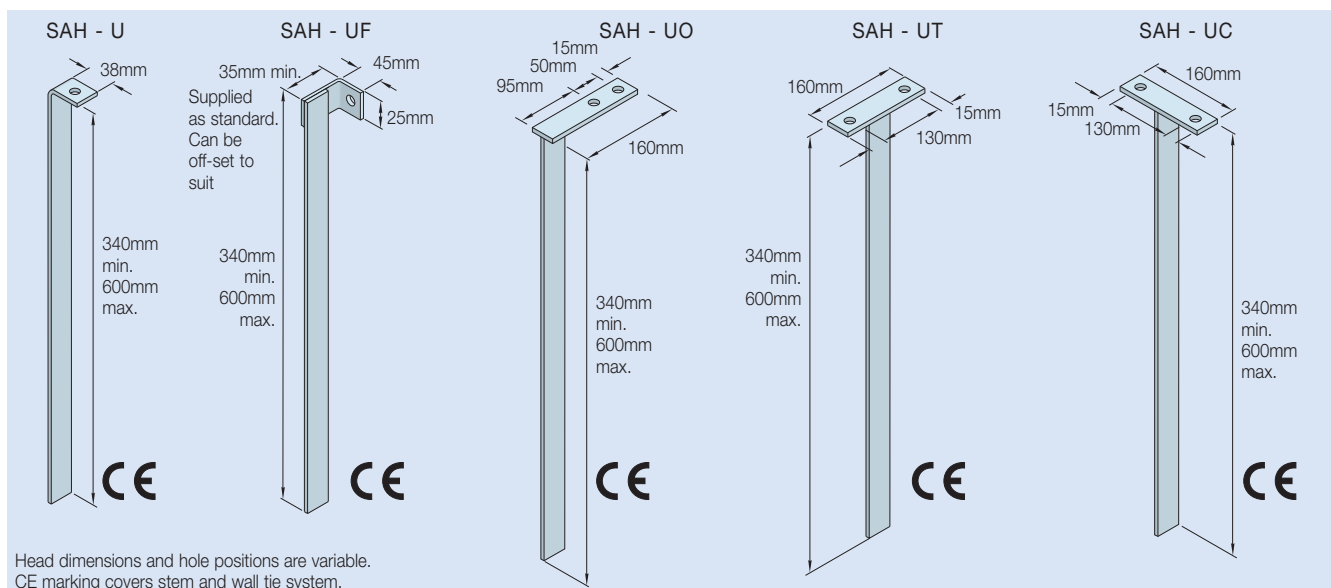

Head dimensions and hole positions are variable. CE marking covers stem and wall tie system.

Wall Ties and Restraint Fixings

Wall Starter Systems

36/8 Wall Extension System

The 36/8 Wall Extension System can be supplied with either SP36 ties or, where some longitudinal movement must be accommodated at the joint, PP36 ties complete with debonding sleeves. The channel can be supplied in lengths of up to 3.4 metres with each length having a series of holes to allow fixing to the existing wall. The system is available as a kit comprising a length of 36/8 channel 2400mm long and ten ties, plugs and screws. It has a design resistance of 1.6kN per metre.



36/8 Wall Extension System, SP36 Tie

Staifix Universal Wall Starter System

This system includes all necessary fixings to join a single skin of masonry, 2400mm high, to an existing wall and is suitable for wall widths from 60mm to 250mm. Each pack includes 2 fixing strips, 5 plugs, 5 washers, 5 screws and 10 wall ties. Wall Ties slide within the fixing strip to course with the bed joints of any masonry unit. This Universal Wall Starter System has a design resistance of 1.7kN per metre and meets the technical requirements of the NHBC.



36/8 Wall Extension System, PP36 Tie



Staifix Universal Wall Starter System

Staifix QuickStart Wall Starter System

This stainless steel system includes all the wall ties and fixings needed to join a new wall, 2400mm high, to existing brickwork and is suitable for wall widths from 60mm to 250mm. The stainless steel starter strip features integral wall ties which fold out at pre-set 225mm vertical centres. Each pack contains 2 starter strips (10 integral wall ties), 5 screws, 5 plugs and 5 washers.

The QuickStart Wall Starter System has a design resistance of 1.7kN per metre and meets the technical requirements of the NHBC.



Staifix QuickStart Wall Starter System

Reveal Support Plate

The Ancon Reveal Support Plate is designed to support the first few bricks of a full brick window reveal during construction. The plate will bond into the bed joint of the outer leaf providing a stable bearing for the reveal brick.

The long leg of the plate should be built into the bed joint of the external leaf with the arrow pointing inwards. To ensure stability, the outer leaf should be built at least one brick high on top of the plate prior to the reveal brick being placed.

For reveals that are larger than one brick deep (102.5mm) please contact Ancon.

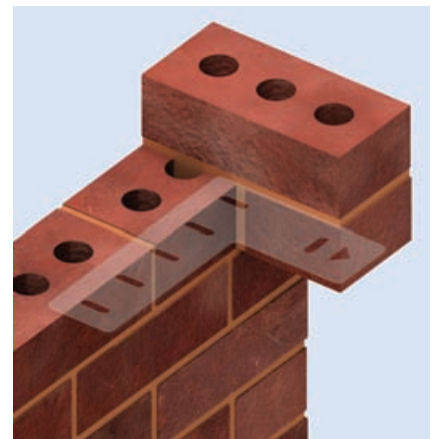

Staifix Cavity Starter Tie

This tie simplifies the building of an inner leaf of blockwork within an existing structure. It is ideal for barn conversions.

The cavity starter tie is a Type 3 tie to PD 6697.

Length mm	Cavity mm	Embedment mm
180	50-70	65-85
200	75-95	65-85
230	100-120	65-85

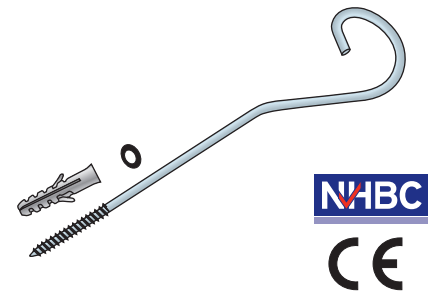
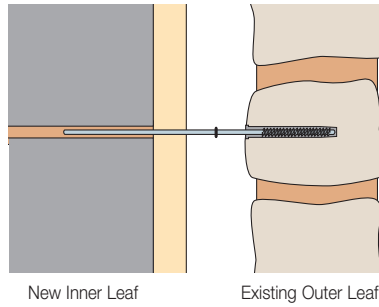

Staifix Starter Tie

This tie is quick and simple to install. It is suitable for use in brickwork and blockwork of up to 3 storeys or 8 metres in height and meets the technical requirements of the NHBC.

Supplied complete with an 8mm nylon wall plug, the Starter Tie is fixed into the existing wall at an angle of 30° to the horizontal and bent into the bed joints of the new brickwork. Ties should be fixed at 225mm vertical centres and be central to each leaf of the new wall.

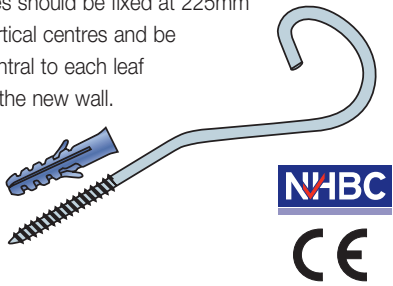

Staifix Frame Tie

The Staifix Frame Tie is used to join timber door and window frames directly to brickwork. It is designed for use on buildings of up to 15 metres in height, and meets the technical requirements of the NHBC. The ties are screwed horizontally into the frame, surrounded by mortar and built into the bed joints of the new brickwork.

The vertical spacing of frame ties depends on the application. Please contact Ancon or your local Staifix stockist for more information.

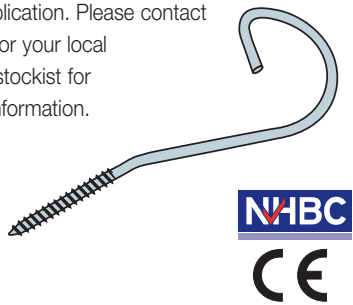

Wall Ties and Restraint Fixings



Buchanan Galleries, Glasgow



Two Ancon YPB Ties Restraining Coping Stone

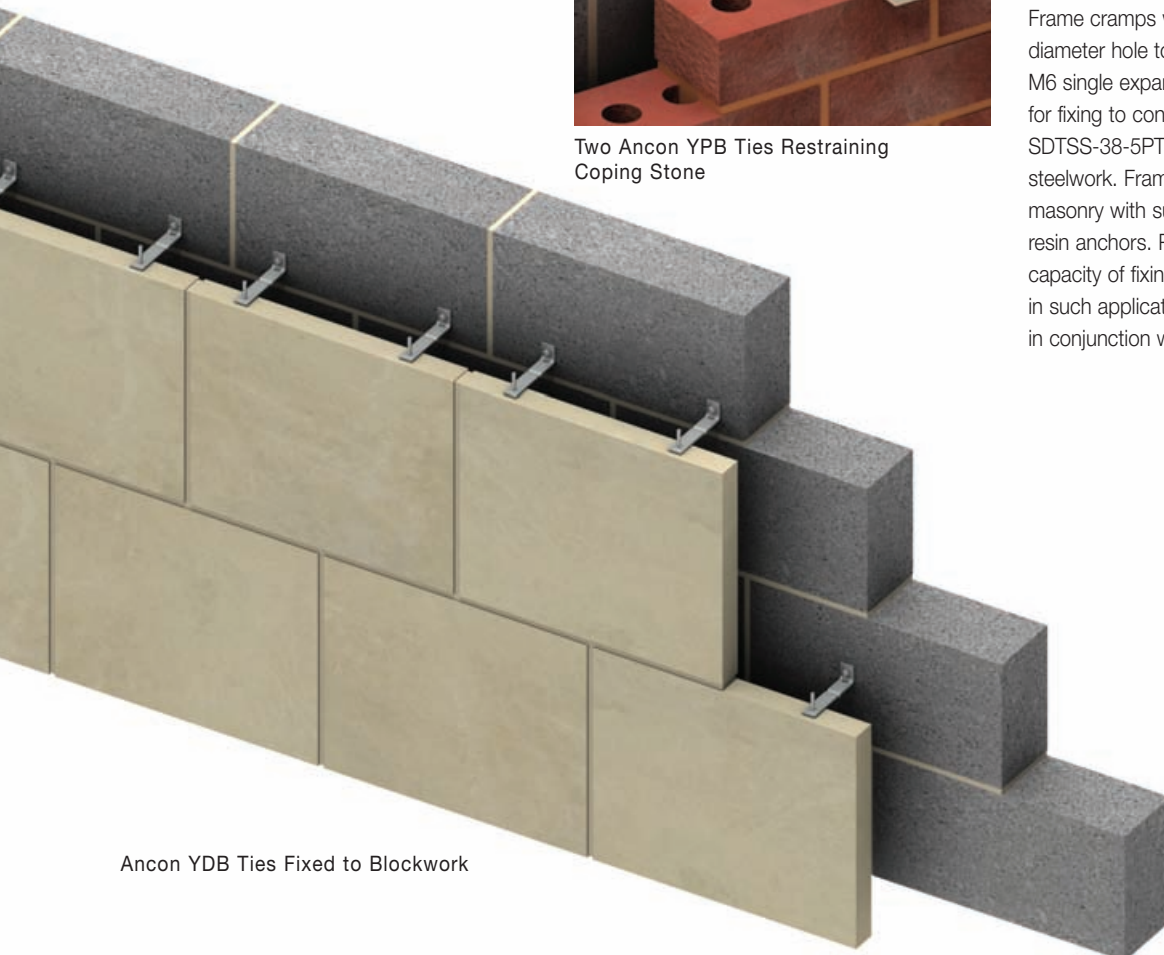

Ancon YDB Ties Fixed to Blockwork

Restraints for Stone Cladding

Reference should be made to BS 8298-2: 2010 "Design and installation of natural stone cladding and lining", when selecting ties for restraining stone cladding. Restraints should be designed to resist wind loads and any imposed loads from, for example, window cleaning equipment.

Each stone will normally be restrained in four places, two at the top and two at the bottom. These are usually situated in the horizontal joints. The restraints should be located in pre-formed mortises or holes positioned in the centre of the thickness of the stone panel, and located at 1/4 points for half bonded stones and 1/5 points for stack bonded stones. Restraints should be kept at least 75mm from any corner with the peripheral distances between any two restraints not exceeding 1200mm.

The embedment of restraint dowels and lips into the stone should be at least 20mm. To achieve this, lipped ties (LPBs) have a 25mm downstand and dowelled ties (DPBs and YPBs) have 60mm long dowels.

The actual capacity of the restraints will normally be restricted by the breaking load of the stone and/or the restraint fixing bolt. Breaking loads at the fixing should be determined in accordance with BS EN 13364.

Frame cramps with a B end have a 7mm diameter hole to suit a range of fixings. Ancon M6 single expansion bolts are recommended for fixing to concrete and M6 set screws or SDTSS-38-5PT self-drilling screws for fixing to steelwork. Frame cramps can be fixed to masonry with suitable plugs and screws or resin anchors. Poor substrates will limit the capacity of fixings and site testing is advisable in such applications. All fixings should be used in conjunction with a DIN washer.

Section of Ties

Restraints for large stones and for use where cavities are in excess of 100mm may require special attention. They may need a much bigger section than standard 20 x 2.5mm; ties formed from 20 x 3mm, 25 x 3mm, 30 x 3mm and 30 x 4mm are frequently used for restraining stone cladding.

Minimum Section of Dowels

Stone Thickness	Minimum Diameter of Dowels
30mm and below	3mm
40mm	5mm
50mm and above	6mm

Drip Position

If a drip is required (e.g. YDB) please specify the position, indicating from which end of the tie the measurement is taken.

Dowels

Standard dowels are 6mm in diameter and 60mm long. These will be welded into the tail end of ties referenced D__, and supplied loose with ties referenced Y__ and the multi-holed M__. 8mm and 10mm diameter dowels are also available upon request, as are longer lengths.

Wire Ties

The traditional method of fixing thin marble, particularly for internal linings and low rise cladding is with wire ties and plaster or mortar dabs. Wire ties are manufactured from 3mm and 5mm diameter wire.



Ancon LD21 Ties Fixed into 21/18 Omega Channel, Restraining Top of Stone

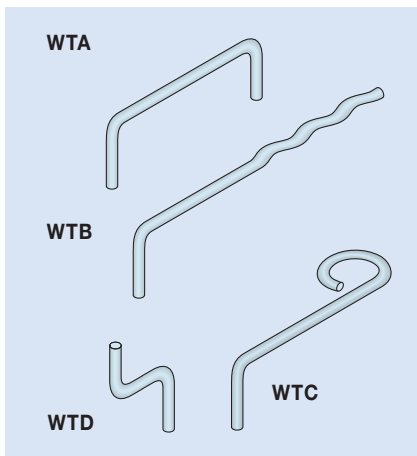

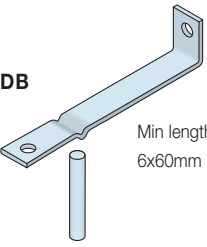
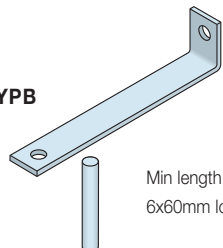
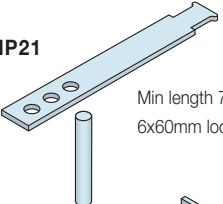
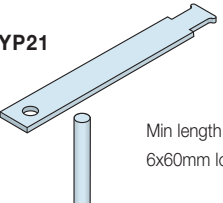
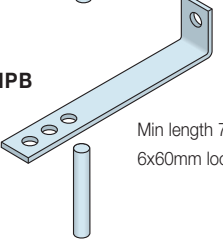
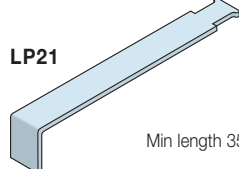
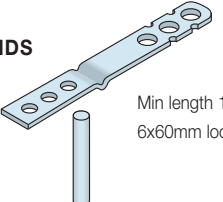
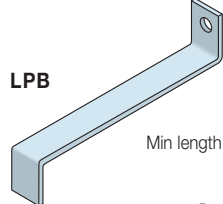
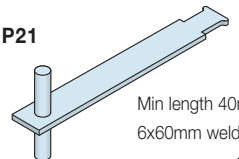
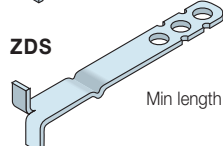
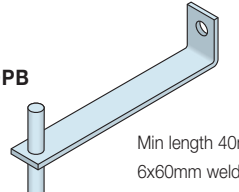
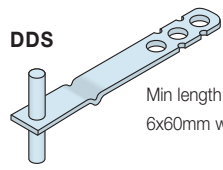
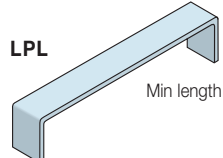
<p>YDB</p>  <p>Min length 120mm 6x60mm loose dowel</p> <p>CE</p>	<p>YPB</p>  <p>Min length 40mm 6x60mm loose dowel</p> <p>CE</p>
<p>MP21</p>  <p>Min length 70mm 6x60mm loose dowel</p> <p>CE</p>	<p>YP21</p>  <p>Min length 40mm 6x60mm loose dowel</p> <p>CE</p>
<p>MPB</p>  <p>Min length 70mm 6x60mm loose dowel</p> <p>CE</p>	<p>LP21</p>  <p>Min length 35mm</p> <p>CE</p>
<p>MDS</p>  <p>Min length 140mm 6x60mm loose dowel</p> <p>CE</p>	<p>LPB</p>  <p>Min length 40mm</p> <p>CE</p>
<p>DP21</p>  <p>Min length 40mm 6x60mm welded dowel</p> <p>CE</p>	<p>ZDS</p>  <p>Min length 110mm</p> <p>CE</p>
<p>DPB</p>  <p>Min length 40mm 6x60mm welded dowel</p> <p>CE</p>	<p>DDS</p>  <p>Min length 120mm 6x60mm welded dowel</p> <p>CE</p>
	<p>LPL</p>  <p>Min length 75mm</p> <p>CE</p>

Wall Ties and Restraint Fixings

Ancon 150

The Ancon 150 is a grout-in masonry tie for the restraint of 20 to 30mm thin facings, and suitable for cavities up to 60mm wide. The 12 x 2mm corrugated body provides optimum bond in a 12 x 90mm hole. The 50 x 3mm dowel is supplied loose.

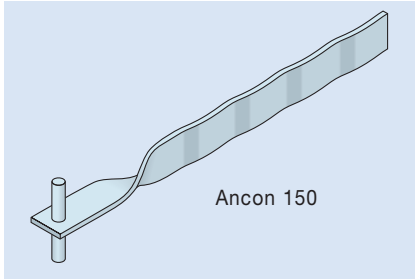

Museum of Scotland, Edinburgh

Ancon Push-Off Bolt

The Push-Off Bolt provides the centre of stone panels with additional resistance to the effects of impact loads, blast loads and positive wind pressure. The Bolt features a mechanical expander at one end which fixes securely into the inner leaf. The external stone panel is positioned with its inner face flush to the bolt's neoprene pad, which cushions the surface and prevents any rattling. The Push-Off Bolt is supplied in a variety of lengths to suit cavities from 100 to 200mm.

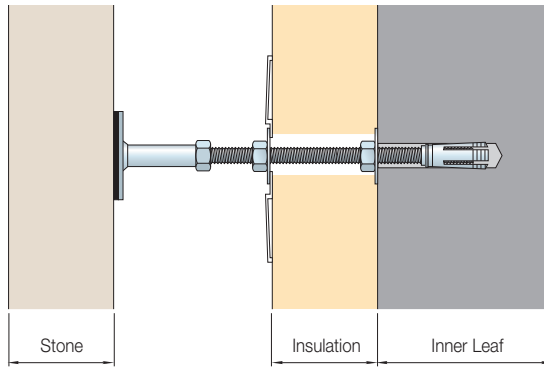
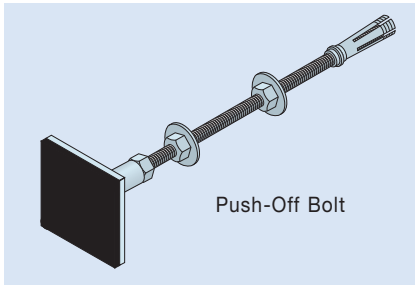

Ancon Push-Off Bolt

Ancon 2000 Thin Facing Restraints

Reference	Facing Thickness (mm)	Min. (mm)	Max. (mm)	Hole Size (mm)	Safe Working Load* (N)
2000/A	20	25	70	8 x 90	600
	25	22	67	8 x 90	600
2000/B	30	30	75	8 x 90	600
	40	25	70	8 x 90	600
2000 - 75	20	60	105	8 x 90	600
	25	57	102	8 x 90	600
	30	55	100	8 x 90	600
	40	50	95	8 x 90	600

Other sizes are available to suit cavities up to 180mm. *In grade 30N/mm² concrete

Ancon 2000

Ancon 2000 restraint fixings are a simple and secure method of fixing thin facing slabs. The fixing is quickly and easily installed with the small diameter hole giving lower drilling costs and minimum disturbance to the structure. Vertical and lateral adjustment is provided by the slotted holes in the fixing clip.

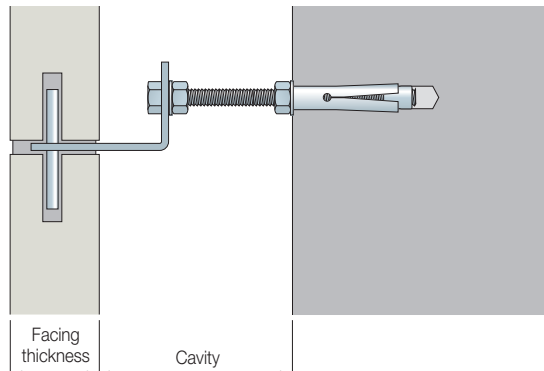
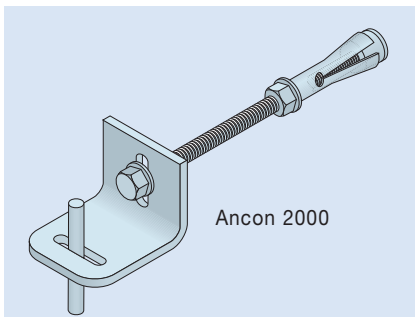

Ancon 2000

Remedial Wall Ties

Corrosion of Cavity Wall Ties

Wall ties are an essential element in the stability of masonry panels. Prior to 1978, wall ties were usually manufactured from galvanised mild steel. These ties were expected to last the lifetime of the building, but for many years it has been recognised that some of these wall ties have corroded after only 15 or 20 years.

When these ties corrode, they can expand to seven times their original thickness. This causes the brickwork to crack at the mortar joints and can result in major damage and sometimes the collapse of walls.

It is crucial that the problem is identified as quickly as possible and the correct remedial action undertaken.

Testing and Tie Performance

The '63 range, Staifix R/R and Teplo2 have been independently tested in a variety of materials; a summary of the results is given in the tables. The failure loads noted are obtained from standard tests in brick couplets and provide indicative values of tie performance.

The couplet test produces results of a conservative nature compared to actual wall tests. Due to the variability of materials, it is advisable to undertake a pull-out test on site to verify the selection of an appropriate tie. Ancon remedial wall ties do not carry CE marking as the test regime in the European Standard EN 845-1 are inappropriate for remedial applications.

Tie Spacing

Accepted practice is to follow PD 6697: 2010 that is 900mm horizontally and 450mm vertically in a staggered pattern with 300mm vertical centres around openings within 225mm of the opening.

Fischer FIS VT 380 C Resin

This CE-marked, two part system of vinyl ester and hardener supplied by Ancon is quick setting and suitable for a wide range of applications. The resin and hardener are stored in separate chambers and are safely mixed together inside the nozzle. Automatic mixing ensures an accurate blend and, being mixed only as required, the minimum of wastage. Dispenser guns and additional static mixing nozzles are available.



Installation of Remedial Wall Ties

Mechanical ties are easily installed by means of two Setting Tools. The tie is fitted to the setting tool for the inner leaf and inserted into a pre-drilled hole in the wall. The required drill depth for each tie is shown in the table below. The inner shell is expanded by turning the handle. The tool for the outer leaf, with a hexagonal-shaped end, is then fitted and adjusted to expand the outer shell. Both tools should be turned until hand tight.

To install Staifix Resin/Resin and TeploTie (Type 2) remedial wall ties an extension nozzle and tube is required to pump resin across the cavity and into the inner leaf. The extension tube is supplied in a standard length of 1000mm and is cut to suit on site.

Ancon 63 Setting Tools

Setting Tool - Outer



Setting Tool - Inner



Ancon 63 Range

Cavity Widths (mm)	Tie Lengths (mm)	Drill Diameter (mm)	Drill Depths (mm)
50-75	200	10	60 min.
76-100	225	10	60 min.
101-125	250	10	60 min.
126-175	300	10	60 min.

Note: For cavities over 100mm horizontal spacing may need to be reduced to 450mm.

Failure Loads (Pull-Out) for the Ancon 63 Range

Base Material	Compressive Strength (N/mm ²)	Failure Load (kN)
Hard Brick (Accrington Nori)	80	5.6
Soft Brick (Yellow Imperial)	30	3.8
Portland Stone	20	5.3
Dense Aggregate Block	7	1.9

Note: Test results are a mean of 5 tests

Failure Loads (Pull-Out) for Staifix R/R

Base Material	Compressive Strength (N/mm ²)	Failure Load (kN)
Dense Concrete Block	7.0 - 10.5	5.78
Lightweight Concrete Block	2.8 - 3.5	2.87
Mortar Bed Joint, 1:1:6 Type (iii) PD 6697	-	5.37

Ancon Teplo2 Range

Cavity Widths (mm)	Tie Lengths (mm)	Drill Diameter (mm)	Tie Diameter (mm)
126-200	275, 300, 325	8	6
201-300	350, 375, 400, 425	10	7

Note: For applications outside those shown above, please contact Ancon.

Failure Loads (Pull-Out) for the Ancon Teplo2 Range

Base Material	Drill Depths (mm)	6mm Tie Failure Load (kN)	7mm Tie Failure Load (kN)
Hard Brick (Accrington Nori)	50-65	8.98	10.03
Soft Brick (Yellow Imperial)	60-65	5.98	8.70
Portland Stone	50-65	6.33	7.21
Lightweight Concrete Block	70 min.	1.35	1.81
Dense Concrete Block	50-65	1.62	1.62

Note: The failure loads given are pull-out tests only. The overall performance of the tie may be limited by other factors such as tie type. For further information please contact Ancon's Technical Department to confirm suitability for specific applications.

Wall Ties and Restraint Fixings

Ancon 63 Mechanical/Mechanical

Used when tying together two leaves of solid materials, this tie has mechanical expanders at each end. Requires 10mm Ø holes.

Ancon 63 Resin/Mechanical

For use when the material in the inner leaf is perforated, of low-density or a friable material. A resin fixing may be used to eliminate any imposed stress. Requires 10mm Ø holes.

Staifix Resin/Resin

Used where mechanical expanders are unusable. Normally inserted into a 10mm Ø hole, but if test facilities are required, a 12mm Ø hole must be used. A plastic sieve can be used to retain resin and is particularly useful in perforated brick or hollow blockwork. A 12mm Ø hole is required to fit the sieve.

Stairib Bar

Stainless steel ribbed bar, resin-grouted into the inner and outer leaves. Requires 10mm Ø hole (6mm dia. bar) or 12mm Ø hole (8mm dia. bar).

Ancon AC 31

Used where bricks are removed then replaced in the outer leaf. The wavy end is resin-bonded into the inner leaf in a 10mm Ø hole. The triangular end sits in the bed joint. Ancon AC 31 can be supplied with a drip or a neoprene ring.

Ancon AC 31C

Similar to the AC 31 but cranked by 25mm to aid fixing to the inner leaf. Requires 10mm Ø holes.

Cameron T 47

Used for the repair of mass brickwork with an unbonded brick façade, sometimes built from snapped headers. The T end is built into the bed joint and perpendicular, and hidden when the brickwork is repointed. Requires 12mm Ø holes.

TeploTie (Type 2)

Basalt fibre wall tie that can be resin-fixed in remedial and retrofit applications. This tie has a thermal conductivity of only 0.7 W/mk. Requires 8mm Ø hole (6mm dia. bar) or 10mm Ø hole (7mm dia. bar).

HRT4/R

Used for tying the two leaves of a cavity wall or separating wall where the first leaf has already been built. The wavy end is resin-bonded into the existing wall in a 10mm Ø hole. The tie is based on the Staifix HRT4 and has similar properties.

Type A R/R

This is designed as a remedial tie for a separating wall. It will normally be inserted in 10mm Ø holes and resin-bonded into both leaves. It meets the requirements of a Type A wall tie to Approved Document E.

Ancon MM 63
 200mm for 50-75mm cavities
 225mm for 76-100mm cavities
 250mm for 101-125mm cavities
 300mm for 126-175mm cavities

Ancon RM 63
 200mm for 50-75mm cavities
 225mm for 76-100mm cavities
 250mm for 101-125mm cavities
 300mm for 126-175mm cavities

Staifix R/R
 180mm for 40-60mm cavities
 200mm for 61-80mm cavities
 220mm for 81-100mm cavities

Stairib Bar
 Length to order
 6, 8mm dia.

Ancon AC 31
 Lengths 175, 200, 225,
 250, 275, 300mm

Ancon AC 31C
 Lengths 175, 200,
 225mm

Cameron T 47
 Lengths 200, 250,
 300mm 4.7mm dia.

TeploTie
 Lengths 275, 300, 325,
 375, 400, 425mm

HRT4/R
 Lengths 200, 225,
 250mm

Type A R/R
 Length 225mm

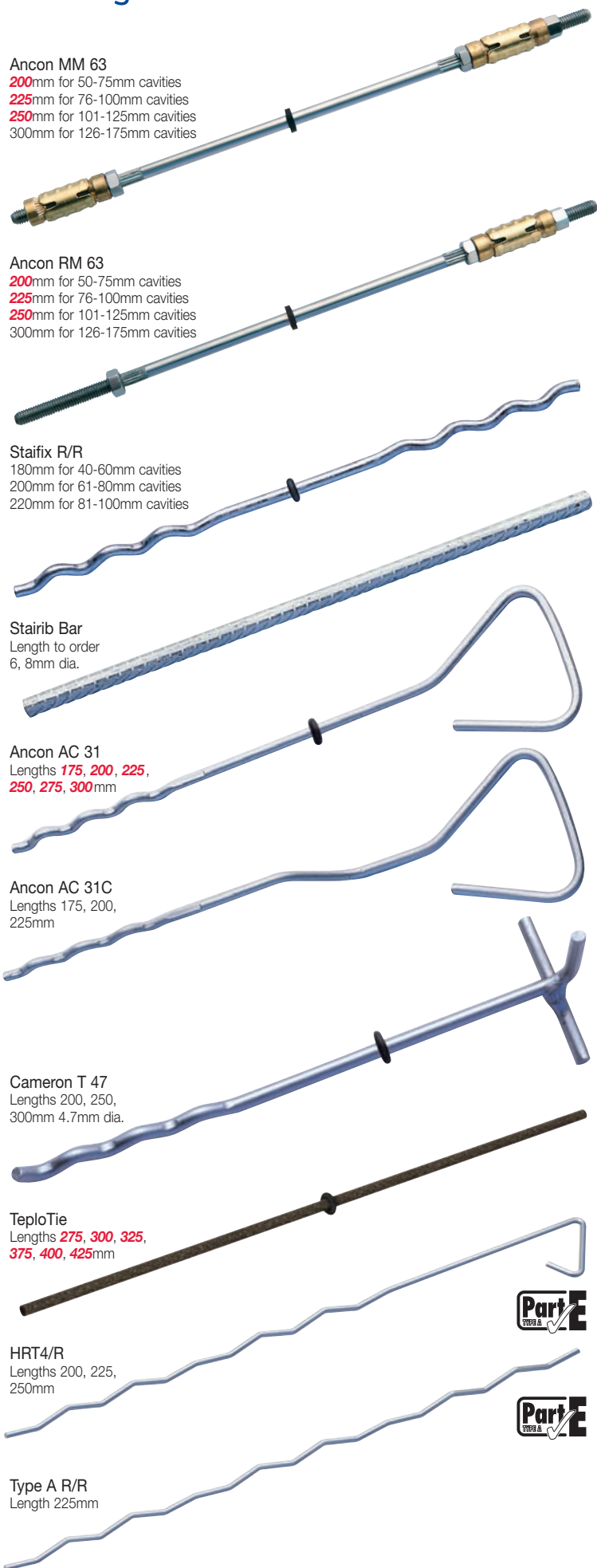

Staifix-Thor Helical Crack Stitching Kit

The Staifix-Thor Helical Crack Stitching Kit is a high strength, non-disruptive solution for the permanent repair of cracked masonry. It is available from builders merchants and specialist distributors.

Ideal for either the remedial specialist or the contractor with a one-off repair job, the kit contains Staifix-Thor Helical reinforcing bars (10 x 1000mm), masonry repair grout (3 litres), a paddle for grout mixing, a grout applicator gun with a flat nozzle, and a finger trowel.



Purchase of the Ancon kit, in preference to obtaining all the components individually, guarantees the correct specification and compatibility of reinforcement, grout and tools for this specific application. The kit is supplied in a single box with full installation instructions.



The stainless steel helical bars are chemically bonded into bed joints to stitch cracks, redistributing tensile forces and stabilising the structure. On completion, the bar and grout are concealed, retaining the original character of the wall.

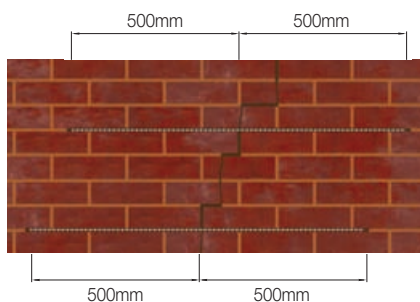

Please note it is essential that the cause of the cracking is established and eliminated prior to the installation of this system.

Other Ancon Products

Masonry Support Systems

Masonry cladding on concrete or steel frames is normally supported from stainless steel support systems. AnconOptima and Ancon MDC Systems create a continuous angle to support the outer leaf of masonry. Ancon Individual Brackets support masonry features such as curves and arches. A full design service is available to specifiers and users of Ancon systems.



Masonry Reinforcement

Ancon AMR masonry reinforcement improves the structural performance of a wall by providing additional resistance to lateral loads. Located in the bed joint, it has a flattened profile to maintain good mortar cover even when lapped or used with wall ties. It is available in various standard configurations to suit a range of loading conditions and wall widths.



Windposts and Parapet Posts

Large panels of masonry or panels with openings can often be difficult to justify structurally. Ancon Windposts are designed to provide additional lateral support for panels of brickwork. The range is manufactured from stainless steel and includes Windposts which can be installed into the inner leaf of blockwork and Windposts for installation into the cavity, which leave the blockwork undisturbed. Parapet Posts are used as vertical support for brickwork in either parapet or spandrel panels.

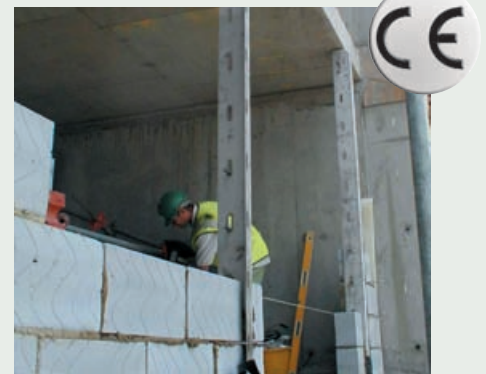

Insulated Balcony Connections

Ancon Isolan connectors join external concrete balconies to internal concrete floor slabs. Used to minimise cold bridging, they provide continuity to the thermal insulation. Standard systems, comprising rigid CFC-free polystyrene insulation and duplex stainless steel shear reinforcement, suit most depths of cantilevered and simply supported balconies. Solutions for steel framed buildings and steel balconies are also available.



Tension and Compression Systems

The use of tie bars in structures and buildings as an architectural as well as a structural element is increasing. Ancon Tension Systems comprise a range of components which can be supplied in carbon steel or stainless steel in a variety of sizes and finishes. The system looks particularly impressive when used with large areas of glazing or timber trusses.



Masonry Support Systems

Lintels

Masonry Reinforcement

Windposts and Parapet Posts

Wall Ties and Restraint Fixings

Channel and Bolt Fixings

Tension and Compression Systems

Insulated Balcony Connectors

Shear Load Connectors

Punching Shear Reinforcement

Reinforcing Bar Couplers

Reinforcement Continuity Systems

Stainless Steel Fabrications

Flooring and Formed Sections

Refractory Fixings



Ancon Building Products

President Way, President Park
Sheffield S4 7UR
United Kingdom
Tel: +44 (0) 114 275 5224
Fax: +44 (0) 114 276 8543
Email: info@ancon.co.uk
Visit: www.ancon.co.uk
Follow on Twitter: @AnconUK

Ancon (Middle East) FZE

PO Box 17225
Jebel Ali
Dubai
United Arab Emirates
Tel: +971 (0) 4 883 4346
Fax: +971 (0) 4 883 4347
Email: info@ancon.ae
Visit: www.ancon.ae

Ancon Building Products

114 Kurrajong Avenue
Mount Druitt
Sydney
NSW 2770
Australia
Tel: +61 (0) 2 8808 1111
Fax: +61 (0) 2 9675 3390
Email: info@ancon.com.au
Visit: www.ancon.com.au

Ancon (Schweiz) AG

Gewerbezone Widalmi 10
3216 Ried bei Kerzers
Switzerland
Tel: +41 (0) 31 750 3030
Fax: +41 (0) 31 750 3033
Email: info@ancon.ch
Visit: www.ancon.ch

Ancon Building Products GesmbH

Puchgasse 1
A-1220 Vienna
Austria
Tel: +43 (0) 1 259 58 62-0
Fax: +43 (0) 1 259 58 62-40
Email: info@ancon.at
Visit: www.ancon.at

Ancon GmbH

Bartholomäusstrasse 26
90489 Nuremberg
Germany
Tel: +49 (0) 911 955 1234 0
Fax: +49 (0) 911 955 1234 9
Email: info@anconbp.de
Visit: www.anconbp.de

These products are available from:

© Ancon Building Products 2013

The construction applications and details provided in this literature are indicative only. In every case, project working details should be entrusted to appropriately qualified and experienced persons.

Whilst every care has been exercised in the preparation of this document to ensure that any advice, recommendations or information is accurate, no liability or responsibility of any kind is accepted in respect of Ancon Building Products.

With a policy of continuous product development Ancon Building Products reserves the right to modify product design and specification without due notice.



ISO 9001: 2008
FM 12226



ISO 14001: 2004
EMS 505377



OHSAS 18001: 2007
OHS 548992

