

MultiJoint System and Individual Plate Dowels

For Ground Bearing Slabs

Ancon[®]
BUILDING PRODUCTS

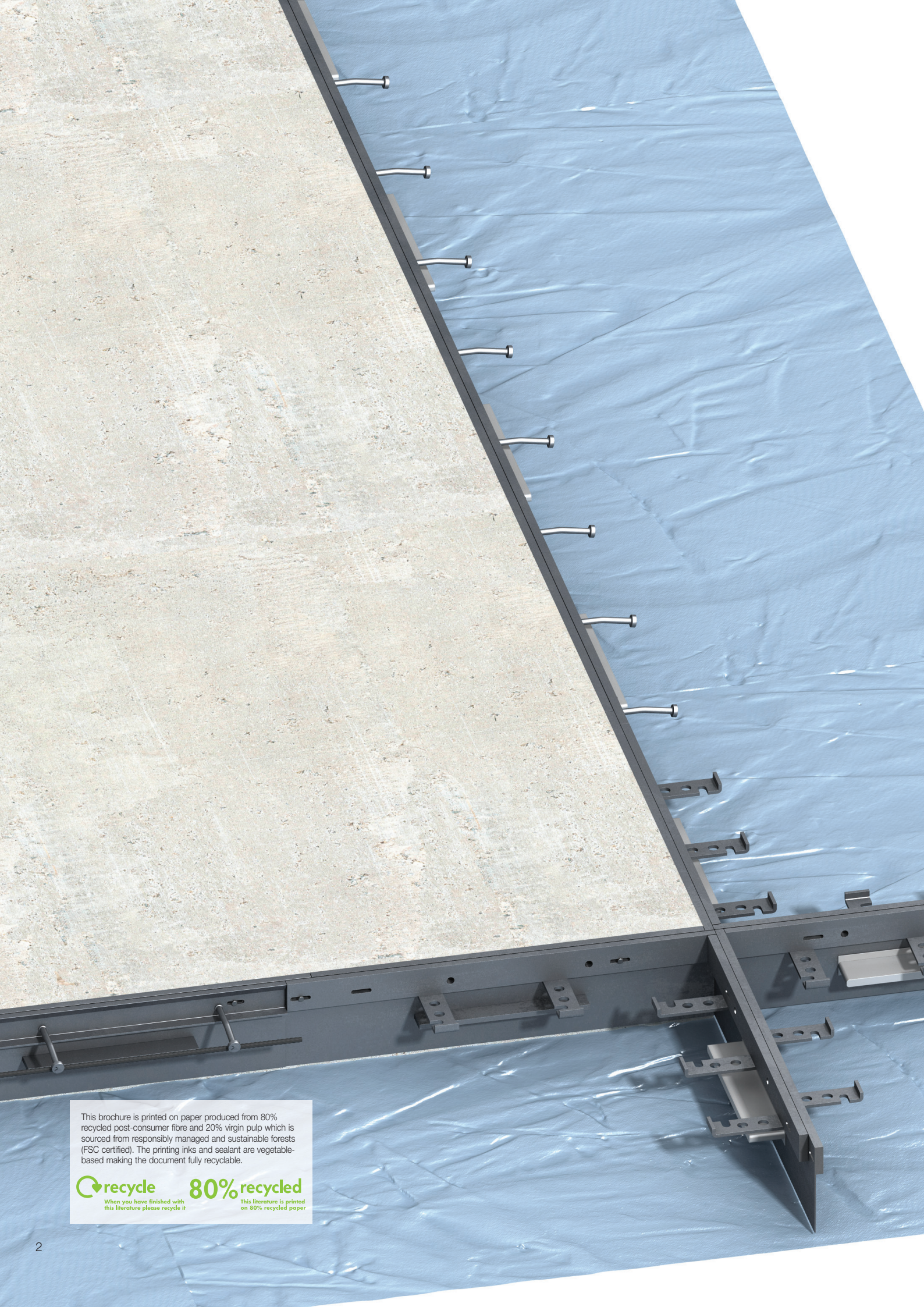

This brochure is printed on paper produced from 80% recycled post-consumer fibre and 20% virgin pulp which is sourced from responsibly managed and sustainable forests (FSC certified). The printing inks and sealant are vegetable-based making the document fully recyclable.



When you have finished with this literature please recycle it

80% recycled

This literature is printed on 80% recycled paper

Ancon designs and manufactures high integrity steel products for the construction industry. Through continuous programmes of new product development, inward investment and employee advancement, the company is committed to maintaining the highest level of customer service within a dynamic and challenging industry.

Plate dowels have replaced plain round and square dowel bars as the preferred method of transferring load in industrial and commercial ground bearing floor slabs.

Ancon MultiJoint has built-in plate dowels and is an all-in-one solution to load transfer, concrete contraction, armoured edge protection and formwork. It is complemented by a range of individual rectangular plate dowels housed in innovative, high strength plastic, tapered sleeves.

Masonry Support Systems	Concrete Floor Contraction Joints	4
Lintels	Introduction to Ancon Systems	4
Masonry Reinforcement	MultiJoint	5-7
Windposts and Parapet Posts	Individual Plate Dowels	8-9
Wall Ties and Restraint Fixings	Installation Guidance	10-11
Channel and Bolt Fixings	Other Ancon Products	11
Tension and Compression Systems		
Insulated Balcony Connectors		
Shear Load Connectors		
Punching Shear Reinforcement		
Reinforcing Bar Couplers		
Reinforcement Continuity Systems		
Stainless Steel Fabrications		
Flooring and Formed Sections		
Refractory Fixings		



ISO 9001: 2008
FM 12226



ISO 14001: 2004
EMS 505377



OHSAS 18001: 2007
OHS 548992



Ancon product information is available in NBS format for easy insertion into a NBS specification



MultiJoint and Individual Plate Dowels

Ancon MultiJoint

FLOOR CONTRACTION JOINTS

The function of a free contraction joint is to allow concrete shrinkage to take place. Although the majority of movement as the concrete contracts is perpendicular to the joint, some relative movement between adjacent bays will also occur along the line of the joint. It is therefore vital that dowels allow for movement in both directions to avoid unnecessary stresses to develop in the slab and ultimately cracking.

Today's concrete floor designs have fewer joints than those in the past. With greater distance between joints, good joint detailing is essential to avoid expensive, premature maintenance.

Plate Dowels

Carbon steel plate dowels are now common in industrial and commercial concrete floor construction. They have replaced debonded round and square dowel bars as the preferred method of accommodating movement and transferring load. Being wider than dowel bars, the bearing stresses between steel and concrete are reduced so greater loads can be carried using plate dowels and, being shorter, they provide improved site access at the joint before the concrete is poured.

Early plate dowel design was based on the North American market where thin tapered dowels, typically 6mm thick, were developed. It is generally acknowledged that this design of plate dowel is inadequate in the joint widths in today's applications. The load transfer performance reduces at a faster rate with a tapered plate dowel than with a rectangular plate dowel.

ANCON PLATE DOWEL SYSTEMS

The Ancon range is suitable for use in ground bearing concrete floor slabs. Load transfer performance is improved when dowels are used in fibre reinforced concrete, when compared to plain or fabric reinforced concrete.

MultiJoint

Ancon MultiJoint is an all-in-one solution to load transfer, concrete contraction, armoured edge protection and formwork. It is ideal for use in factories, warehouses, distribution centres and other applications where floor slabs are subject to high loads and wheeled traffic. Its use can minimise slab depth, saving time and materials, and prevent uneven vertical settlement between slabs (pages 5-7).

Individual Plate Dowels

In addition to the MultiJoint system, Ancon also manufactures a range of individual rectangular plate dowels, housed in innovative, high strength plastic sleeves. These dowels can be used where arris protection is not required or as part of a site-assembled system with the patented MultiJoint top profile if a steel joint edge is required (pages 8-9).

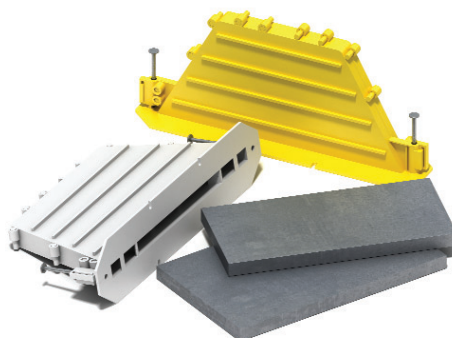

Ancon Individual Plate Dowels



Technical and Sales Support

Ancon designs and manufactures a wide range of engineered dowel systems for use at concrete expansion and contraction joints.

The company is a member of the Concrete Society, Construct concrete structures group and the Association of Contract Industrial Flooring Contractors.

Ancon will advise on the most cost-effective and practical dowel system for the design load, final joint width and slab construction

details of individual concrete floors. Technical enquiries should be sent to tech@ancon.co.uk.

Ancon has a dedicated sales team for the concrete sector. Email concrete@ancon.co.uk or call +44 (0) 114 275 5224 for sales support.

Material

All steel shown in this literature is plain carbon steel. For galvanised steel or stainless steel products please contact Ancon.

Further Reading

Technical Report No.34 (TR34), Concrete Industrial Ground Floors – A Guide to Design and Construction

This document offers guidance on the design of internal concrete floors which are outside the scope of EN 1992-1-1: 2004 (Eurocode 2).

BS8204-2: 2002 Screeds, bases and in-situ floorings – Concrete wearing surfaces –

This code of practice requires that metal armoured joints be considered for all free contraction joints in heavy duty applications.



ANCON MULTIJOINT

The MultiJoint system is an all-in-one solution to load transfer, concrete contraction, armoured edge protection and formwork in ground bearing floor slabs. It is a prefabricated steel system supplied in a standard three metre unit length and is available in four heights to suit slab depths from 150mm. Units are simply lapped end-to-end on site.

A unique patented top rail transfers load into the concrete at an angle, to avoid localised cracking.

Prefabricated corner units provide continuity in joint aris protection at the most vulnerable area of the slab. Standard four-way and three-way profiles are available, with non-standard intersections manufactured on request. See page 6 for dimensions.

Tabulated performance data is shown on page 7 for a slab depth up to 350mm and a joint width up to 40mm.

System Components

Rectangular plate dowels pass through the steel formwork and are housed in moulded plastic sleeves. The number and dimensions of the plate dowels have been engineered to provide the most effective combination of concrete and steel resistance for load transfer. Dowel centres are 600mm. The sleeves allow lateral and longitudinal movement.

The top profile comprises two square-edged 12mm wide steel strips which provide heavy-duty joint edge protection. The unique, patented design creates a sharp joint edge and transfers impact loads into the concrete at a 45° angle to avoid localised cracking.

The nylon fasteners, used to link the back-to-back profiles, strip as the joint opens allowing concrete contraction to take place.

Studs are welded at 225mm horizontal centres to provide anchorage in the concrete, resisting rotation and vertical movement as load is applied.

A rebar is welded to the studs on one side of the unit for extra rigidity and ease of handling.

Specification Clause

Delete italicised text as necessary.

Armoured contraction joints to be MultiJoint MJ-SL80 / MJ-SL110 / MJ-SL130 / MJ-SL160 from Ancon Building Products.

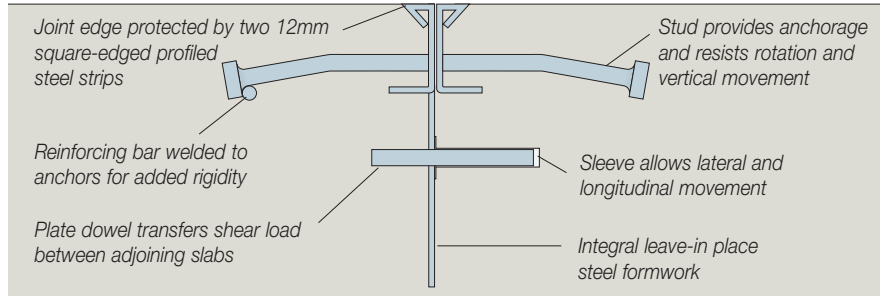

Cross-section view

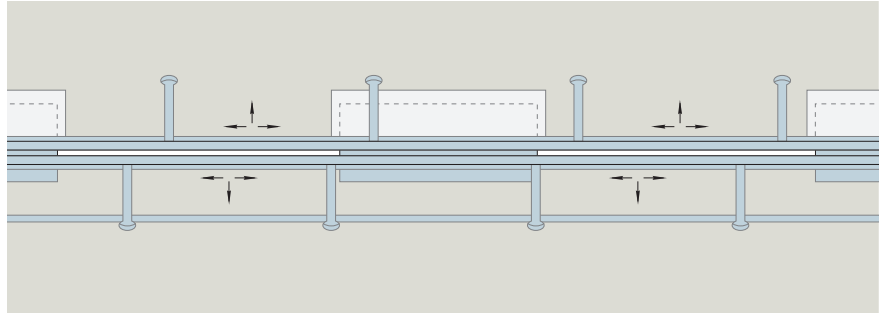

Plan view

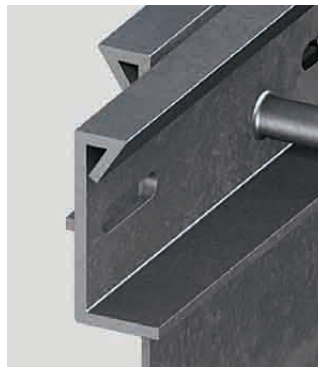

Unique, Square-Edged Profile
Patent No. EP1756367

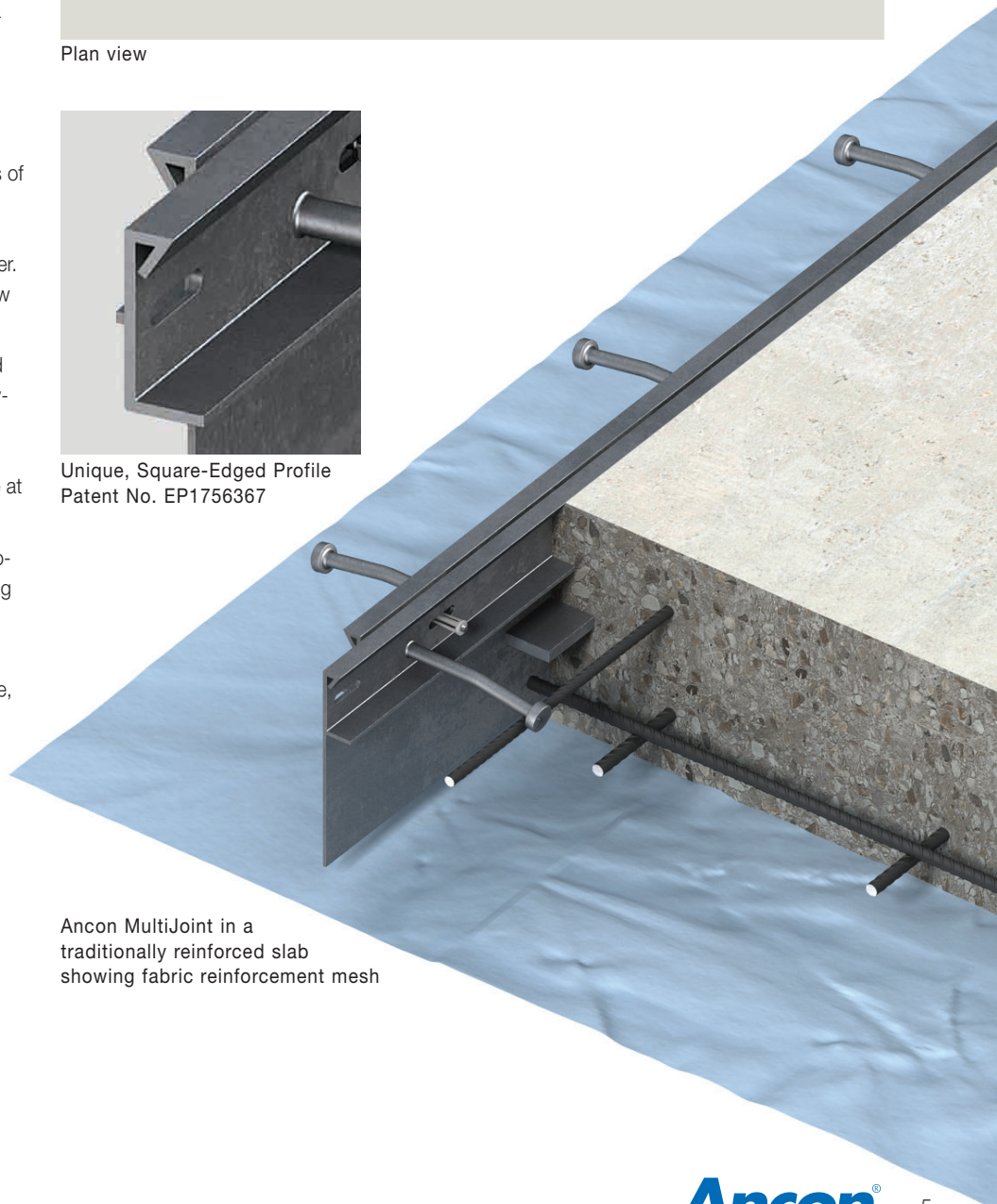

Ancon MultiJoint in a traditionally reinforced slab showing fabric reinforcement mesh

MultiJoint and Individual Plate Dowels

DIMENSIONS

Standard MultiJoint Unit

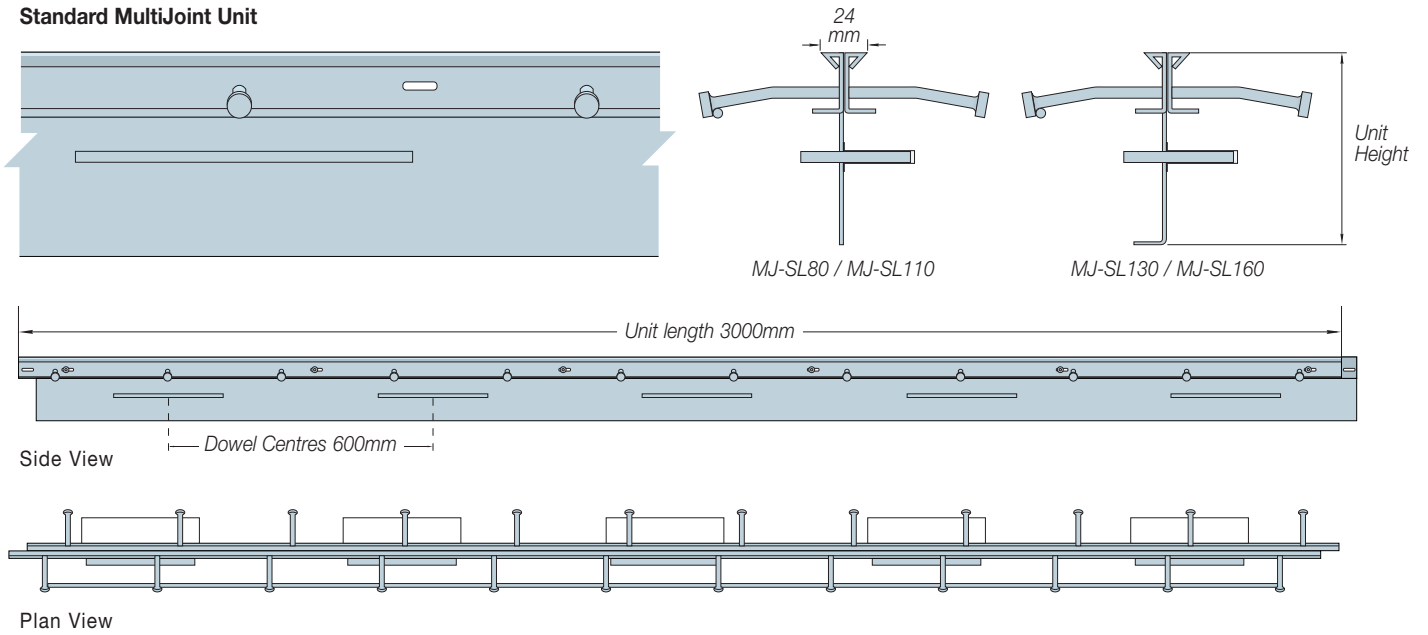

Standard T and X MultiJoint Intersections

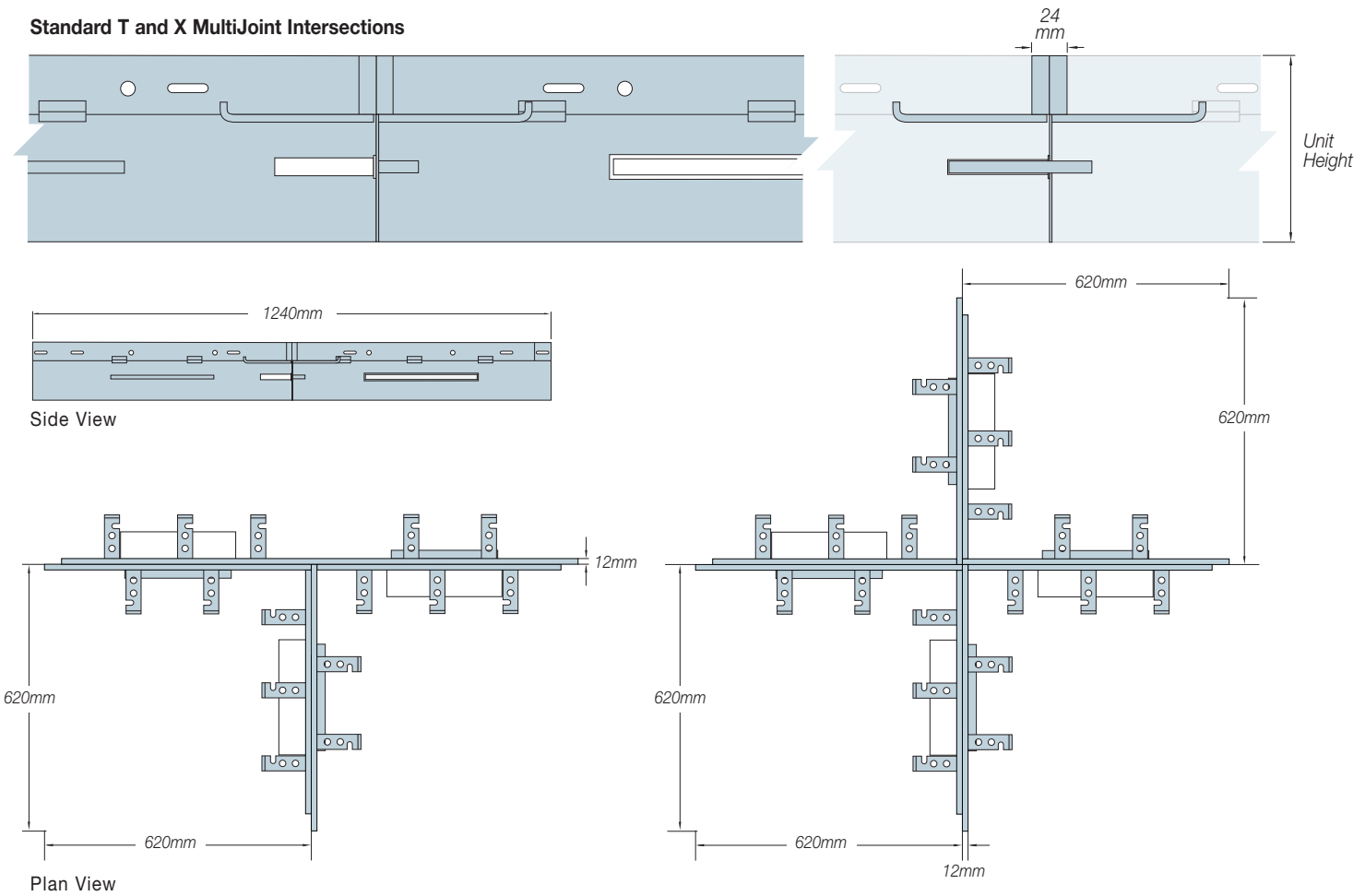

MultiJoint Reference	Unit Length	Unit Height	Slab Depth		Dowel Centres	Compatible Intersections	
			Min	Max		T Junction Ref	X Junction Ref
MJ-SL80	3000mm	140mm	150mm	200mm	600mm	MJ-SL80-T	MJ-SL80-X
MJ-SL110	3000mm	190mm	200mm	250mm	600mm	MJ-SL110-T	MJ-SL110-X
MJ-SL130	3000mm	240mm	250mm	300mm	600mm	MJ-SL130-T	MJ-SL130-X
MJ-SL160	3000mm	290mm	300mm	350mm	600mm	MJ-SL160-T	MJ-SL160-X

Non-standard heights can be manufactured for deeper slabs.

PERFORMANCE

Please contact Ancon for applications outside the parameters shown in these tables.

Plain / Traditionally Reinforced Concrete**Design Resistance (kN/m) for Various Joint Widths (mm) and Slab Depths (mm) using C32/40 Concrete**

Ref	Slab Depth (mm)	Joint Widths (mm)							
		5	10	15	20	25	30	35	40
MJ-SL80	150	53.7	53.7	53.7	53.7	53.0	52.3	51.6	50.9
	160	56.0	56.0	56.0	56.0	55.3	54.6	53.9	52.2
	170	56.0	56.0	56.0	56.0	55.3	54.6	53.9	53.2
	180	56.0	56.0	56.0	56.0	55.3	54.6	53.9	53.2
	190	56.0	56.0	56.0	56.0	55.3	54.6	53.9	53.2
	200	56.0	56.0	56.0	56.0	55.3	54.6	53.9	53.2
MJ-SL110	200	61.3	61.3	61.3	61.3	61.3	61.3	61.3	55.3
	210	64.6	64.6	64.6	64.6	64.6	64.6	64.6	55.3
	220	65.4	65.4	65.4	65.4	65.4	65.4	65.4	55.3
	230	65.4	65.4	65.4	65.4	65.4	65.4	65.4	55.3
	240	65.4	65.4	65.4	65.4	65.4	65.4	65.4	55.3
	250	65.4	65.4	65.4	65.4	65.4	65.4	65.4	55.3
MJ-SL130	250	73.9	73.9	73.9	73.9	73.9	73.9	73.9	55.3
	260	74.9	74.9	74.9	74.9	74.9	74.9	74.9	55.3
	270	74.9	74.9	74.9	74.9	74.9	74.9	74.9	55.3
	280	74.9	74.9	74.9	74.9	74.9	74.9	74.9	55.3
	290	74.9	74.9	74.9	74.9	74.9	74.9	74.9	55.3
	300	74.9	74.9	74.9	74.9	74.9	74.9	74.9	55.3
MJ-SL160	300	84.7	84.7	84.7	84.7	84.7	84.7	84.7	84.7
	310	90.0	90.0	90.0	90.0	90.0	90.0	90.0	90.0
	320	90.0	90.0	90.0	90.0	90.0	90.0	90.0	90.0
	330	90.0	90.0	90.0	90.0	90.0	90.0	90.0	90.0
	340	90.0	90.0	90.0	90.0	90.0	90.0	90.0	90.0
	350	90.0	90.0	90.0	90.0	90.0	90.0	90.0	90.0

Steel Fibre Reinforced Concrete ($R_{e,3} = 0.8$)**Design Resistance (kN/m) for Various Joint Widths (mm) and Slab Depths (mm) using C32/40 Concrete**

Ref	Slab Depth (mm)	Joint Widths (mm)							
		5	10	15	20	25	30	35	40
MJ-SL80	150	92.3	92.3	92.3	92.3	91.1	89.9	77.4	55.3
	160	96.4	96.4	96.4	96.4	95.1	90.3	77.4	55.3
	170	96.4	96.4	96.4	96.4	95.1	90.3	77.4	55.3
	180	96.4	96.4	96.4	96.4	95.1	90.3	77.4	55.3
	190	96.4	96.4	96.4	96.4	95.1	90.3	77.4	55.3
	200	96.4	96.4	96.4	96.4	95.1	90.3	77.4	55.3
MJ-SL110	200	105.5	105.5	105.5	105.5	105.5	90.3	77.4	55.3
	210	110.5	110.5	110.5	110.5	108.4	90.3	77.4	55.3
	220	111.4	111.4	111.4	111.4	108.4	90.3	77.4	55.3
	230	111.0	111.0	111.0	111.0	108.4	90.3	77.4	55.3
	240	110.5	110.5	110.5	110.5	108.4	90.3	77.4	55.3
	250	110.1	110.1	110.1	110.1	108.4	90.3	77.4	55.3
MJ-SL130	250	124.3	124.3	124.3	124.3	108.4	90.3	77.4	55.3
	260	125.5	125.5	125.5	125.5	108.4	90.3	77.4	55.3
	270	125.0	125.0	125.0	125.0	108.4	90.3	77.4	55.3
	280	124.6	124.6	124.6	124.6	108.4	90.3	77.4	55.3
	290	124.2	124.2	124.2	124.2	108.4	90.3	77.4	55.3
	300	123.9	123.9	123.9	123.9	108.4	90.3	77.4	55.3
MJ-SL160	300	140.0	140.0	140.0	140.0	140.0	140.0	121.0	105.9
	310	148.4	148.4	148.4	148.4	148.4	141.1	121.0	105.9
	320	147.9	147.9	147.9	147.9	147.9	141.1	121.0	105.9
	330	147.6	147.6	147.6	147.6	147.6	141.1	121.0	105.9
	340	147.2	147.2	147.2	147.2	147.2	141.1	121.0	105.9
	350	146.8	146.8	146.8	146.8	146.8	141.1	121.0	105.9

MultiJoint and Individual Plate Dowels

ANCON INDIVIDUAL PLATE DOWELS

Ancon individual plate dowels are a cost-effective means of transferring shear loads and accommodating movement in load bearing ground floors. They are typically installed at 600mm horizontal centres and are ideal when arris protection is not required.

The innovative tapered sleeves allow greater longitudinal dowel movement as the concrete contracts and joint width increases.

The Ancon ADD 75/10 is suitable for the majority of applications, however where a greater capacity is required or wider than average joint widths are anticipated, the Ancon AHM 100/10 system should be considered. The larger steel plate of this system provides a greater surface area to reduce bearing stresses on the concrete. This dowel typically provides a 30% increase in capacity for joints of over 20mm in slabs greater than 250mm.

Tabulated performance data is shown on page 9 for a slab depth up to 350mm and a joint width up to 40mm. Contact Ancon for applications outside these parameters.

Installation is a quick and simple process (see page 11). The sleeve is fixed to the formwork and cast in with the first pour. The dowel is inserted into the sleeve, once the formwork is removed.



When compared with plain round dowels or armoured joint systems with integral plate dowels, the use of individual plate dowels can improve site access. The sub-base can be compacted and accurately levelled along the full line of the joint, prior to the dowel component being installed.

Specification Clause

Delete italicised text as necessary.

ADD 75/10 or AHM 100/10 from Ancon Building Products to be installed at the contraction joint, in the centre line of the slab, at XXXmm centres.

Joint Edge Protection

The unique top profile of the Ancon MultiJoint system can be supplied with a nailing plate welded to the underside to facilitate its use with timber formwork. This item is ideal for applications requiring both an armoured joint edge and flexibility in the positioning of shear load dowels.

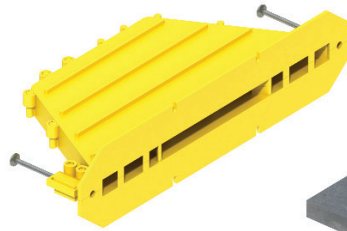
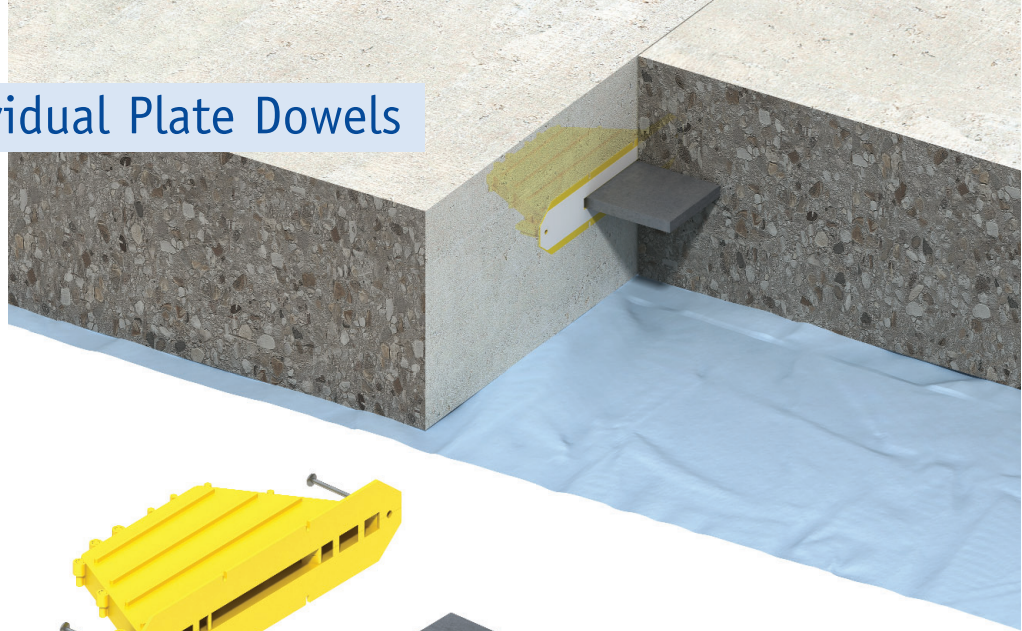

Ancon Dominator® Dowel (ADD 75/10)

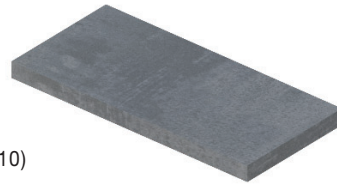

Ancon Hi-Move® Dowel (AHM 100/10)

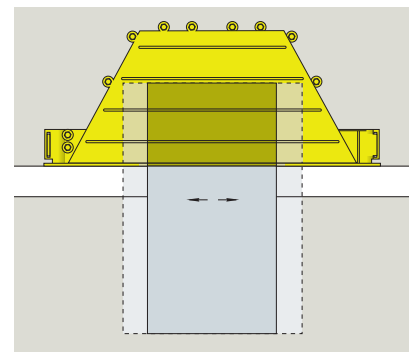
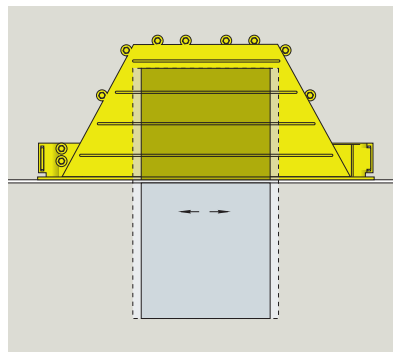
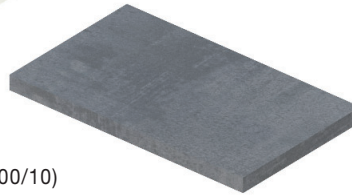

Allowable longitudinal dowel movement increases as concrete contracts



MultiJoint Top Profile used with Individual Plate Dowel



Item Code: MJ-SLC-3000
Patent no. EP1756367

Plain / Traditionally Reinforced Concrete

Maximum Design Resistances (kN) for Various Joint Widths (mm) and Slab Depths (mm) using C32/40 Concrete

Ref	Slab Depth (mm)	Minimum Dowel Centres (mm)	Joint Widths (mm)							
			5	10	15	20	25	30	35	40
ADD 75/10	150	380	29.2	28.8	28.4	28.0	27.6	25.5	21.9	19.2
	160	400	32.6	32.2	31.7	31.3	30.7	25.5	21.9	19.2
	170	420	36.1	35.7	35.2	34.7	30.7	25.5	21.9	19.2
	180	440	39.8	39.3	38.8	36.7	30.7	25.5	21.9	19.2
	190	460	43.7	43.2	42.7	36.7	30.7	25.5	21.9	19.2
	200	480	47.8	47.2	44.2	36.7	30.7	25.5	21.9	19.2
	210	500	52.0	51.4	44.2	36.7	30.7	25.5	21.9	19.2
	220	520	56.4	55.7	44.2	36.7	30.7	25.5	21.9	19.2
	230	540	61.0	55.7	44.2	36.7	30.7	25.5	21.9	19.2
	240	560	65.8	55.7	44.2	36.7	30.7	25.5	21.9	19.2
	250	580	70.7	55.7	44.2	36.7	30.7	25.5	21.9	19.2
	275	630	75.0	55.7	44.2	36.7	30.7	25.5	21.9	19.2
	300	680	75.0	55.7	44.2	36.7	30.7	25.5	21.9	19.2
	350	780	75.0	55.7	44.2	36.7	30.7	25.5	21.9	19.2
AHM 100/10	150	405	30.7	30.3	29.9	29.5	29.0	28.6	28.2	25.5
	160	425	34.2	33.7	33.3	32.8	32.4	31.9	29.2	25.5
	170	445	37.8	37.3	36.8	36.4	35.9	34.1	29.2	25.5
	180	465	41.6	41.1	40.6	40.1	39.6	34.1	29.2	25.5
	190	485	45.6	45.1	44.5	44.0	40.9	34.1	29.2	25.5
	200	505	49.7	49.2	48.6	48.1	40.9	34.1	29.2	25.5
	210	525	54.1	53.5	52.9	48.9	40.9	34.1	29.2	25.5
	220	545	58.6	58.0	57.4	48.9	40.9	34.1	29.2	25.5
	230	565	63.3	62.6	59.0	48.9	40.9	34.1	29.2	25.5
	240	585	68.1	67.5	59.0	48.9	40.9	34.1	29.2	25.5
	250	605	73.2	72.5	59.0	48.9	40.9	34.1	29.2	25.5
	275	655	86.5	74.3	56.0	48.9	40.9	34.1	29.2	25.5
	300	705	100.3	74.3	58.0	48.9	40.9	34.1	29.2	25.5
	350	805	100.3	74.3	59.0	48.9	40.9	34.1	29.2	25.5

Steel Fibre Reinforced Concrete ($R_{e,3} = 0.8$)

Maximum Design Resistances (kN) for Various Joint Widths (mm) and Slab Depths (mm) using C32/40 Concrete

Ref	Slab Depth (mm)	Minimum Dowel Centres (mm)	Joint Widths (mm)							
			5	10	15	20	25	30	35	40
ADD 75/10	150	380	50.3	49.6	44.2	36.7	30.7	25.5	21.9	19.2
	160	400	56.1	55.3	44.2	36.7	30.7	25.5	21.9	19.2
	170	420	62.1	55.7	44.2	36.7	30.7	25.5	21.9	19.2
	180	440	68.5	55.7	44.2	36.7	30.7	25.5	21.9	19.2
	190	460	75.0	55.7	44.2	36.7	30.7	25.5	21.9	19.2
	200	480	75.0	55.7	44.2	36.7	30.7	25.5	21.9	19.2
	210	500	75.0	55.7	44.2	36.7	30.7	25.5	21.9	19.2
	220	520	75.0	55.7	44.2	36.7	30.7	25.5	21.9	19.2
	230	540	75.0	55.7	44.2	36.7	30.7	25.5	21.9	19.2
	240	560	75.0	55.7	44.2	36.7	30.7	25.5	21.9	19.2
	250	580	75.0	55.7	44.2	36.7	30.7	25.5	21.9	19.2
	275	630	75.0	55.7	44.2	36.7	30.7	25.5	21.9	19.2
	300	680	75.0	55.7	44.2	36.7	30.7	25.5	21.9	19.2
	350	780	75.0	55.7	44.2	36.7	30.7	25.5	21.9	19.2
AHM 100/10	150	405	52.8	52.1	51.4	48.9	40.9	34.1	29.2	25.5
	160	425	58.8	58.0	57.2	48.9	40.9	34.1	29.2	25.5
	170	445	65.0	64.2	59.0	48.9	40.9	34.1	29.2	25.5
	180	465	71.6	70.7	59.0	48.9	40.9	34.1	29.2	25.5
	190	485	78.4	74.3	59.0	48.9	40.9	34.1	29.2	25.5
	200	505	85.6	74.3	59.0	48.9	40.9	34.1	29.2	25.5
	210	525	92.5	74.3	59.0	48.9	40.9	34.1	29.2	25.5
	220	545	99.8	74.3	59.0	48.9	40.9	34.1	29.2	25.5
	230	565	100.3	74.3	59.0	48.9	40.9	34.1	29.2	25.5
	240	585	100.3	74.3	59.0	48.9	40.9	34.1	29.2	25.5
	250	605	100.3	74.3	59.0	48.9	40.9	34.1	29.2	25.5
	275	655	100.3	74.3	59.0	48.9	40.9	34.1	29.2	25.5
	300	705	100.3	74.3	59.0	48.9	40.9	34.1	29.2	25.5
	350	805	100.3	74.3	59.0	48.9	40.9	34.1	29.2	25.5

DESIGN EXAMPLE

Project Requirements

Reinforcement: Traditional Fabric
Concrete Strength: C32/40
Slab Depth: 200mm
Joint Width: 20mm
Design Load: 74.5kN/m

Dowel Options

Ancon ADD 75/10 = 36.7kN
 $36.7 / 74.5 = 0.493$
Use Ancon ADD 75/10 at 480mm horizontal centres, taking care not to reduce the spacing beyond the minimum centres in the table.
Ancon AHM 100/10 = 48.1kN
 $48.1 / 74.5 = 0.645$
Use Ancon AHM 100/10 at 600mm horizontal centres.

MultiJoint and Individual Plate Dowels

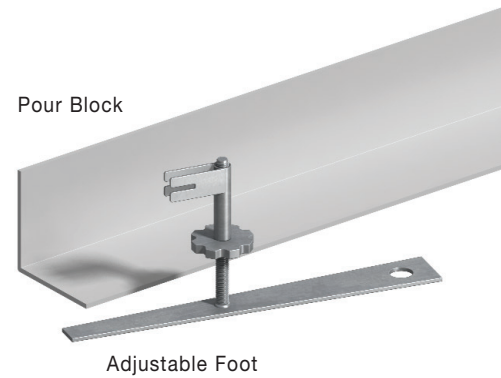
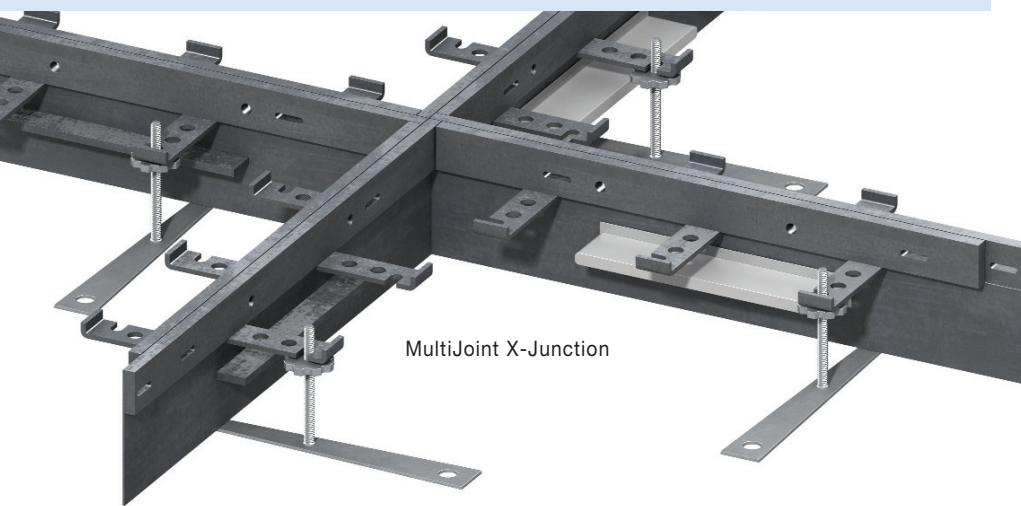

INSTALLATION GUIDANCE

MultiJoint

Joint layout and height is specified on slab drawings. These details should be accurately marked-out in string initially, to provide a clear visual guide. Installation of the MultiJoint system should begin either at an intersection or at a column/wall.

Irrespective of type or size, all MultiJoint units are connected end-to-end in the same way. The top steel strips are overlapped and a mechanical fixing, supplied with the system, is located through the slots.

Adjustable feet are available to level and support the MultiJoint units. By turning the shaped nut on the threaded section of the foot, the system height is adjusted. The feet should be located on the opposite side of the joint to the first pour.

Working from both ends of a run, the final section to be installed will be at a mid-point. MultiJoint units are supplied in standard three

metre lengths, so the final section will usually be cut to length.

As work progresses, consistency in joint height should be checked with a laser level and vertical straightness verified with a spirit level.

To keep the feet stable during the pour, rebar pins should be driven into the sub-base at an angle, through the hole in the flat.

The MultiJoint unit height will be 10mm to 60mm less than the slab depth. At the higher end of this range, it may be necessary to minimise concrete egress below a MultiJoint system. This can be achieved with the Ancon Pour Block, a robust L-shaped board which is positioned directly on the sub-base on the side of the pour. Dimensions and item codes are shown in the table.

Once the concrete reaches sufficient strength and the joint no longer requires support, the rebar pins are removed and each foot is pulled clear.

Adjustable Feet

Item Code	Compatible MultiJoint Units/ Intersections
MJ-FT80	MJ-SL80 / MJ-SL80-X / MJ-S80-T
MJ-FT110	MJ-SL110 / MJ-SL110-X / MJ-SL110-T
MJ-FT130	MJ-SL130 / MJ-SL130-X / MJ-SL130-T
MJ-FT160	MJ-SL160 / MJ-SL160-X / MJ-SL160-T

Note: The barrel on the threaded section is removed when used with MultiJoint intersections. Available ex-stock.

Pour Block

Item Code	Width x Height x Length
APB80	80mm x 80mm x 3000mm

Note: Suitable for use with all MultiJoint unit heights and intersections. Available ex-stock.

Calculating cut-to-length sections

Measure length of gap (g_l). Must be less than 3000mm.



Gap in mid-point of MultiJoint Run

Subtract the dimension g_l from a full three metre length as shown below. Make two cuts so end sections form length g_l when butted together. Cuts must never be made through a plate dowel and should be repositioned accordingly.

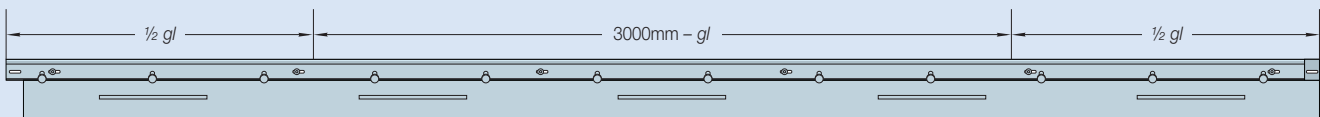

Standard 3000mm MultiJoint Section

The outer edges of the g_l section are overlapped and joined as normal to the MultiJoint run. The central join is a butt joint.

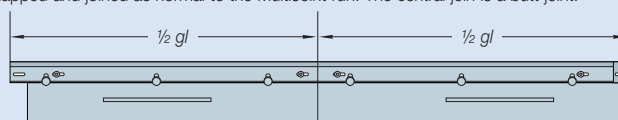

MultiJoint Cut-To-Length Section

Individual Plate Dowels

Built-in ring shanked nails on Ancon sleeves make installation a quick and easy process.

1. Fix the sleeve to the formwork using the nails provided, at the required depth and spacing (normally on the centre line of the slab, typically at 450-600mm horizontal centres). Do not remove the protective strip on the nailplate as this protects the sleeve from concrete ingress.

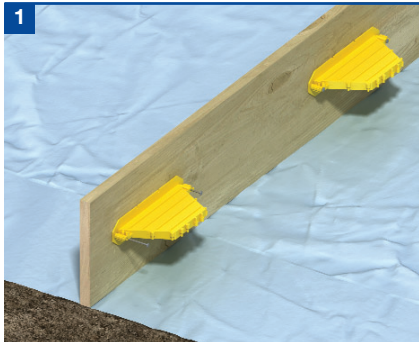

2. Fix fabric reinforcement if required. Pour concrete, ensuring good coverage around the sleeve component.



3. When concrete reaches sufficient strength, strike the formwork. New sub-base can be accurately levelled and compacted right up to the slab edge. Flatten nails and insert the dowel into the sleeve by puncturing the protective strip.



4. Place reinforcement if required and proceed with the second pour, again ensuring good coverage of concrete around the plate dowel.

OTHER ANCON PRODUCTS

Shear Load Connectors

Ancon DSD and DSDQ double-dowel connectors are used to transfer shear across movement joints in suspended concrete slabs. They are more effective at transferring load and allowing movement than standard single dowels and can be used to eliminate double columns at structural movement joints in buildings. The Q version features a rectangular box section to allow lateral and some rotational movement. A lockable dowel is now available for temporary movement joints in post-tensioned concrete frames.



Punching Shear Reinforcement

Ancon Shearfix is used within a slab to provide additional reinforcement from punching shear around columns. The system consists of double-headed steel studs welded to flat rails and is designed to suit the load conditions and slab depth at each column using free calculation software from Ancon.



Reinforcing Bar Couplers

The use of reinforcing bar couplers can provide significant advantages over lapped joints. Design and construction of the concrete can be simplified and the amount of reinforcement can be reduced. The Ancon range includes parallel-threaded, tapered-threaded and mechanically-bolted couplers.



Reinforcing Continuity Systems

Ancon Eazistrip is approved by UK CARES and consists of bent bars housed in a galvanised steel casing. Once installed, the protective cover is removed and the bars straightened ready for joining. As an alternative, Ancon Starter Bars are rebar lengths supplied fixed to an Ancon coupler which can be cast into the face of the concrete.



Insulated Balcony Connectors

Ancon Isolan connectors provide a thermal break between an internal concrete floor slab and an external concrete balcony to minimise cold bridging. Standard systems comprising rigid CFC-free polystyrene insulation and duplex stainless steel shear reinforcement suit most depths of cantilevered and simply supported balconies.



Channel & Bolts for Fixing to Concrete

Cast-in channels are available in different sizes ranging from simple self-anchoring slots for use with wall ties to large capacity anchors with integral anchors; some sizes are available plain-backed for surface fixing. Expansion bolts and resin anchors complete the range.



Ancon Building Products

President Way, President Park
Sheffield S4 7UR
United Kingdom
Tel: +44 (0) 114 275 5224
Fax: +44 (0) 114 276 8543
Email: info@ancon.co.uk
Visit: www.ancon.co.uk

Ancon (Middle East) FZE

PO Box 17225
Jebel Ali
Dubai
United Arab Emirates
Tel: +971 (0) 4 883 4346
Fax: +971 (0) 4 883 4347
Email: info@ancon.ae
Visit: www.ancon.ae

Ancon Building Products

114 Kurrajong Avenue
Mount Druitt
Sydney
NSW 2770
Australia
Tel: +61 (0) 2 8808 1111
Fax: +61 (0) 2 9675 3390
Email: info@ancon.com.au
Visit: www.ancon.com.au

Ancon (Schweiz) AG

Gewerbezone Widalmi 10
3216 Ried bei Kerzers
Switzerland
Tel: +41 (0) 31 750 3030
Fax: +41 (0) 31 750 3033
Email: info@ancon.ch
Visit: www.ancon.ch

Ancon Building Products GesmbH

Gerspergasse 9/3 Top 1
A-1210 Vienna
Austria
Tel: +43 (0) 1 259 58 62-0
Fax: +43 (0) 1 259 58 62-40
Email: info@ancon.at
Visit: www.ancon.at

Ancon GmbH

Bartholomäusstrasse 26
90489 Nuremberg
Germany
Tel: +49 (0) 911 955 1234 0
Fax: +49 (0) 911 955 1234 9
Email: info@anconbp.de
Visit: www.anconbp.de

These products are available from:

© Ancon Building Products 2010

This brochure is printed on paper produced from 80% recycled post-consumer fibre and 20% virgin pulp which is sourced from responsibly managed and sustainable forests (FSC certified). The printing inks and sealant are vegetable-based making the document fully recyclable.



80% recycled
This literature is printed on 80% recycled paper

The construction applications and details provided in this literature are indicative only. In every case, project working details should be entrusted to appropriately qualified and experienced persons.

Whilst every care has been exercised in the preparation of this document to ensure that any advice, recommendations or information is accurate, no liability or responsibility of any kind is accepted in respect of Ancon Building Products.

With a policy of continuous product development Ancon Building Products reserves the right to modify product design and specification without due notice.



ISO 9001: 2008
FM 12226



ISO 14001: 2004
EMS 505377



OHSAS 18001: 2007
OHS 548992