

CI/SIB		X16	
July 2013			



Tension and Compression Systems for the Construction Industry



ETA-06/0146
BS EN 1090-1

Ancon[®]
BUILDING PRODUCTS

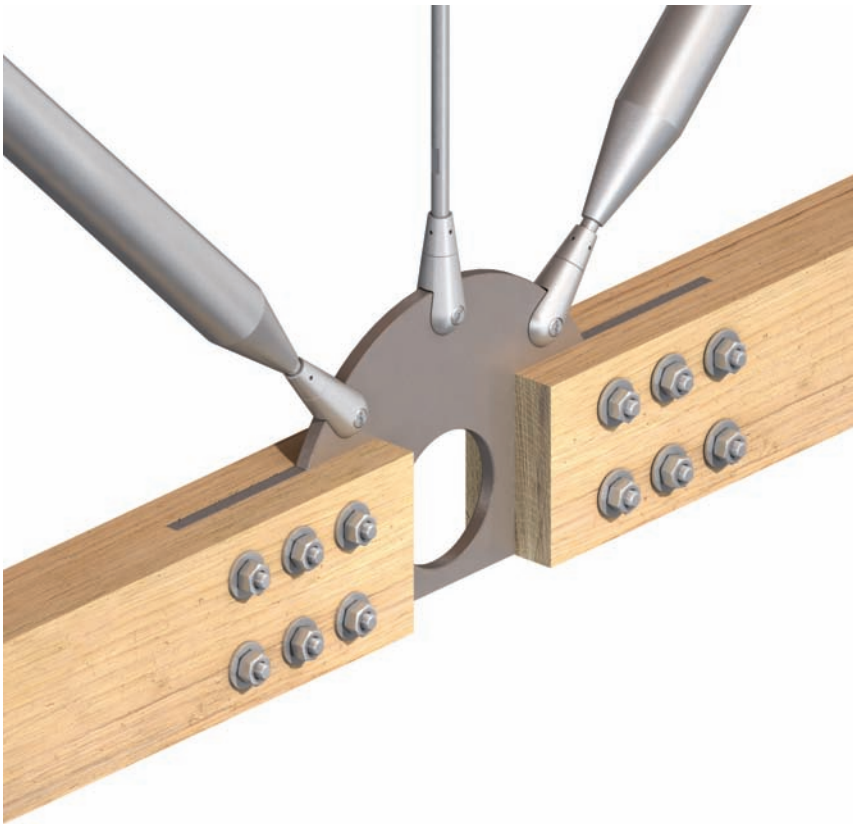

CE

ETA-06/0146
BS EN 1090-1

Ancon designs and manufactures high integrity steel products for the construction industry. Through continuous programmes of new product development, inward investment and employee advancement, the company is committed to maintaining the highest level of customer service within a dynamic and challenging industry.

Tie bars are increasingly being used in structures and buildings as an architectural as well as a structural element.

In addition to providing a high load capacity, the Ancon 500 Tension System meets the demanding aesthetic requirements of today's applications.

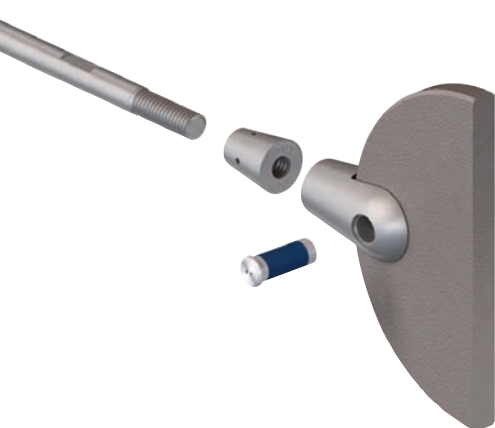

Masonry Support Systems

Lintels

Masonry Reinforcement

Windposts and Parapet Posts

Wall Ties and Restraint Fixings

Channel and Bolt Fixings

**Tension and
Compression Systems**

Stainless Steel Fabrications

Flooring and Formed Sections

Shear Load Connectors

Reinforcing Bar Couplers

Reinforcement Continuity Systems

Punching Shear Reinforcement

Insulated Balcony Connectors

Refractory Fixings

Ancon Tension Systems	4
Carbon Steel Systems	4
Stainless Steel Systems	5
Ancon Compression Systems	5
System Components	6-7
Applications	8-9
Performance and Dimensions	10-12
Connecting Plates	13
Specifying and Ordering	13
Installation Guidance	14-15
Other Ancon Products	15



ISO 9001: 2008
FM 12226



ISO 14001: 2004
EMS 505377



OHSAS 18001: 2007
OHS 548992

NBSPlus

Ancon product information is available in NBS format for easy insertion into a NBS Specification

Tension and Compression Systems

TENSION & COMPRESSION SYSTEMS

The use of new materials and forming processes have enabled cast components to be produced which are not only functional, strong and durable, but also aesthetically pleasing. Ancon manufactures a range of components that can be used to create a variety of assemblies, from simple tie bars to complex bracing systems involving several bars joined at one point. Unlike standard tie bars that require turnbuckles, adjustment to the length is accommodated within the fork connectors.

APPROVALS AND CE MARKING

Ancon Tension Systems conform to the provisions of European Technical Approval ETA-06/0146. Ancon Compression Systems are manufactured in accordance with EN 1090: Execution of Steel Structures and Aluminium Structures, to Execution Class 2.

These products are supplied with CE marking to demonstrate compliance with the relevant document which, in both cases, includes the initial inspection and on-going surveillance of Ancon's factory production controls (FPC) by an authorised body.

Visit www.ancon.co.uk/CE to access all associated documentation including Declarations and third party FPC certificates.



Ancon 500 Tension System

The Ancon 500 Tension System combines aesthetic appearance with high performance. It is available in various sizes from 8mm to 42mm in both carbon steel and stainless steel.

All components of the system can be supplied in a variety of finishes to provide corrosion resistance and to meet the demanding aesthetic requirements of many architectural applications. The bar used in this system has a minimum yield of 500N/mm².

- ✓ CE marked to European Technical Approval
- ✓ High load capacity
- ✓ Carbon steel or stainless steel
- ✓ Bars from 8mm to 42mm diameter
- ✓ Choice of finishes
- ✓ Aesthetically designed forks
- ✓ Locking nut included as standard
- ✓ Full adjustment within fork connectors
- ✓ Visual check of correct installation
- ✓ Isolation supplied as standard with stainless steel systems



Ancon 500 Tension System Carbon Steel

The carbon steel Ancon 500 System is suitable for most applications requiring a cost-effective solution. Bars are available in nine diameters from 8mm to 42mm. Performance details are shown on page 10. Bars are either untreated, zinc plated or hot-dip galvanised and are available in most sizes up to 6 metres in length. The availability of each size of bar is given on page 11. The system can be extended over the maximum bar length by the inclusion of couplers or anchor discs. Discs are supplied in the same range of surface finishes as the bars. All fork connectors and locking nuts are zinc plated as standard to provide a basic resistance to corrosion. The fork connectors and couplers are designed to allow adjustments to be made to the system length without the need for turnbuckles.

Other finishes, in addition to those mentioned above, are available on request. All systems are suitable for painting, which Ancon recommends is carried out insitu rather than prior to installation to ensure threads and other recesses are unaffected.

Ancon 360 Tension System Carbon Steel

The Ancon 360 System is available in two sizes for applications requiring a bar diameter above 42mm. This carbon steel system extends the Ancon range to 56mm and a capacity of 712kN. Similar in appearance to the Ancon 500, this system uses bar with a minimum yield strength of 360N/mm². All technical details for the Ancon 360, including performance details, dimensions and the available lengths of each size of bar are shown adjacent to the Ancon 500 on pages 10 and 11.

Ancon 500 Tension System Stainless Steel

The stainless steel Ancon 500 System is recommended for applications that demand corrosion resistance and a maintenance-free life, or where an attractive, polished finish is required. Stainless steel bars in nine diameters can be supplied, in most cases, in lengths up to 6 metres. Performance details are shown on page 10 and the availability of each size of bar is given on page 11. The system can be extended over the maximum bar length by the inclusion of couplers or anchor discs. The fork connectors and couplers are designed to allow adjustments to be made to the system length without the need for turnbuckles.

Surface finish is usually an important factor in applications using stainless steel. Ancon bars are bright drawn as standard but can be hand polished if required. The stainless steel forks

and locking nuts can be supplied electro-polished, satin-polished or hand polished. The photographs below provide a good indication of the available finishes; actual finishes may differ slightly. Couplers and anchor discs are supplied with a smooth machined finish as standard, and can be satin-polished or hand polished when required. All available finishes and order codes are shown on page 13.

Isolation System

Isolation material is supplied as standard with the stainless steel system to enable its fixing to a connecting plate of a dissimilar metal. Each stainless steel fork connector is supplied with two clear, self-adhesive, PET (polyester) washers to be applied around the fixing hole either side of the structure. Stainless steel pins feature a PTFE coating around the barrel.

Ancon Compression Systems

To complement the Tension System range, Ancon designs and manufactures Compression Systems. These systems use the same fork connectors and locking nuts as the Tension System but use high strength tubes instead of bars. They are available in both carbon and stainless steels in a variety of sizes and finishes. To enable Ancon to design a compression system the following information is required:

- Pin to pin dimension
- Applied system load
- Material and surface finish required

For further information on Compression Systems please contact Ancon.

Electro-polished
stainless steel fork
and locking nut with
bright drawn bar



Satin-polished stainless
steel fork and locking nut
with bright drawn bar



Hand polished stainless
steel fork, locking nut
and bar



Hand polished
stainless steel
compression system

Tension and Compression Systems



SYSTEM COMPONENTS

The wide range of components available can be used to create a variety of assemblies, from simple tie bars to complex bracing systems involving several bars joined at one point.

Fork Connectors & Locking Nuts

Ancon fork connectors are supplied with a locking nut which provides a neat transition from bar to fork. Forks and their locking nuts have left or right hand threads, and are supplied complete with a pin. They are stamped with the size and either the letter R or L to identify the hand of the thread.

The locking nuts firmly lock the bar to the fork and ensure that the connection remains secure. The internally threaded section of the locking nut is recessed to allow the threaded end of the bar to be hidden when the installation is complete.

Adjustments to the length of the system can still be made after installation without a turnbuckle, by loosening the locking nut and rotating the bar. The extent of this adjustment depends on the size of the bar, but will range from $\pm 9\text{mm}$ for an Ancon 500/8 to $\pm 45\text{mm}$ for an Ancon 360/56.

Carbon steel forks and locking nuts are zinc plated as standard. Stainless steel forks and locking nuts are electro-polished as standard and can also be supplied satin or hand polished.

Each stainless steel fork is supplied with two clear, self-adhesive, PET (polyester) washers to isolate the system from a connecting plate of a dissimilar metal.

Pins

The pins are a two-part construction and once installed are flush with the fork. The installation requires a twin-pin driver. Two driver bits of the appropriate size are supplied with each Ancon system. This type of fixing, known as 'Snake Eyes'*[†], allows a high torque to be achieved without damage to the pin.

The female section of the pin is located through the fork connector and temporarily held in position. A second driver is then used to wind the male section into position creating a secure connection.

Stainless steel pins are supplied with a PTFE coating around the barrel, as illustrated, to isolate the system from a connecting plate of a dissimilar metal.

Anchor Discs

Anchor discs allow up to eight bars to be connected together. They can be used at the centre of conventional cross bracing, or where several bars need to be connected at one point. Anchor discs are machined from plate and can be supplied polished or coated to match the surface finish of the tie bars. Ancon can design and manufacture plates in special shapes to replace standard anchor discs and suit the aesthetic requirements of an application.



Tie Bars

Tie bars have a right-hand thread at one end and a left-hand thread at the other. Flats are pressed into the bar close to each end. These allow the bar to be screwed into the fork connectors and adjustments to be made at any time after assembly. Neither couplers nor turnbuckles will be required for applications using a single bar between two forks. The bar is correctly installed when all threads are hidden within the locking nut.

The availability of each size of bar is given on page 11. All bars are cut to a tolerance of $\pm 2\text{mm}$ of the specified length.

Carbon steel bars are available either untreated, with the electrodeposited zinc coating Fe//Zn12//A to EN 12329 or are hot-dip galvanised to EN 1461.

Stainless steel bars are bright drawn as standard or hand polished when required.

Compression Systems

Ancon designs and manufactures Compression Systems which comprise the standard fork connectors and pins shown on page 6 and high strength tubes, rather than the tie bars, shown above. The same selection of materials and surface finishes are available. For more information please contact Ancon.

Couplers

Couplers have right and left hand threads and are used in applications where more than one tie bar is required between forks. They are supplied with a locking nut for each end of the coupler. Adjustments to the length of the system can still be made after installation, by loosening the locking nut and rotating the bar.

Couplers are machined from bar and can have the provision for a hanger to be fitted to limit the deflection of bars of 16mm diameter or greater. If a hanger is required a lug is welded to the coupler. Stainless steel couplers can be supplied with a polished finish to match the system.



Untreated bar

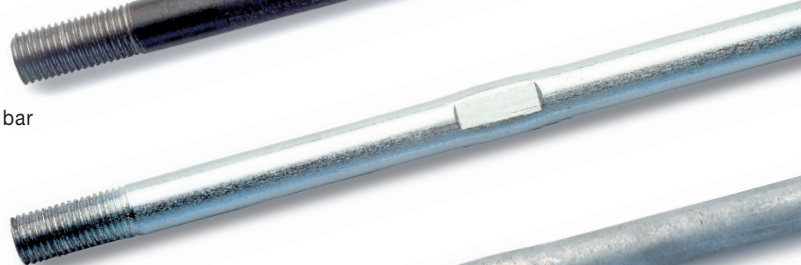

Zinc plated bar



Hot-dipped galvanised bar

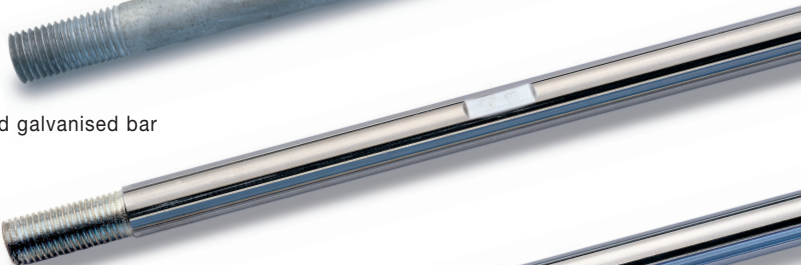

Bright drawn bar

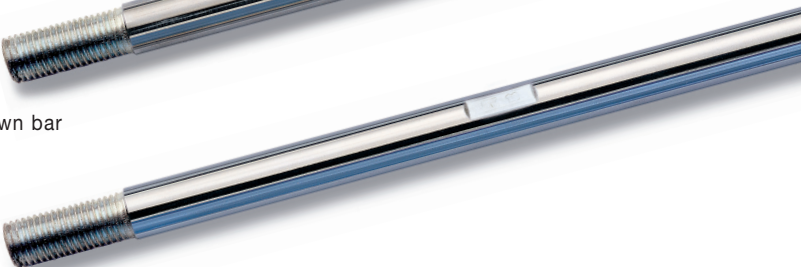

Hand polished bar

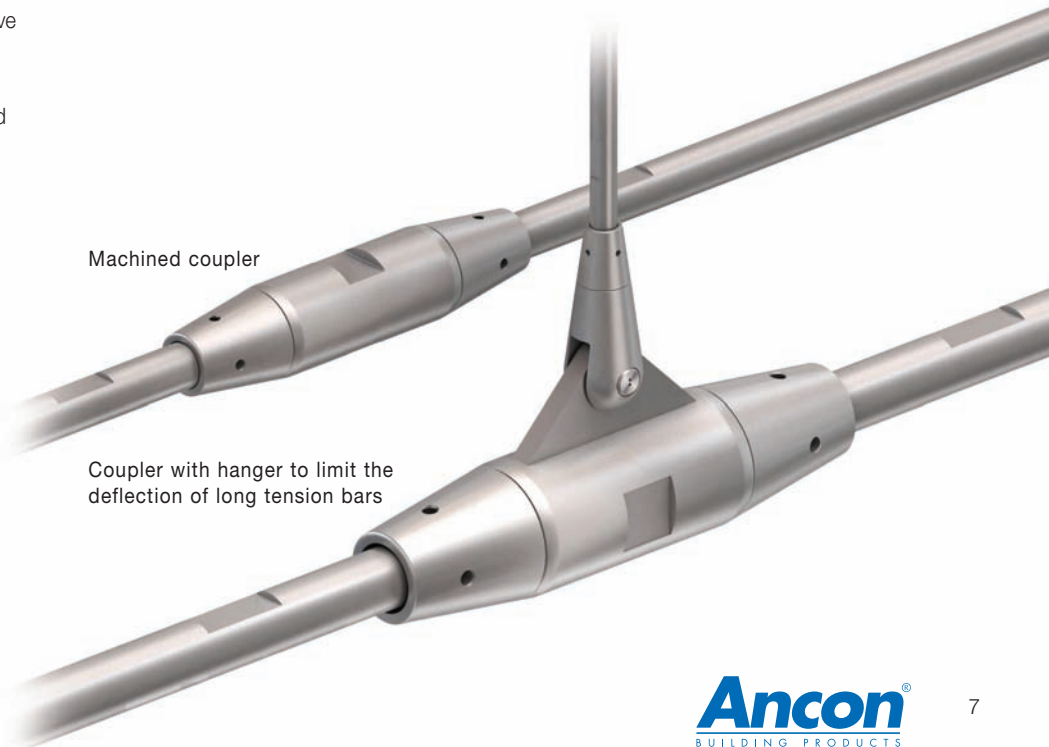

Machined coupler

Coupler with hanger to limit the deflection of long tension bars

Tension and Compression Systems

APPLICATIONS

Ancon has supplied Tension and Compression Systems to many structures and buildings. The wide range of components can be used to create a variety of assemblies, from simple tie bars to complex bracing systems involving several bars joined at one point. The following applications demonstrate the variety of uses.



Timber Construction

A combination of timber and steel can use the best properties of each material and achieve a cost-effective and attractive design. Ancon Tension Systems can be connected to timber compression members, and if high loads are involved, several bars can be used together.

Roof Structures

Trusses and lattice frames which support roofs can benefit from the replacement of tension members with the Ancon system. This will allow generous site adjustments to be made to accommodate inaccuracies within the frame. This would not be possible with a conventionally bolted frame.



Canopies

Canopies are frequently supported from above to provide unobstructed access below. Ancon tension bars transfer the load from the front of the canopy back to the main structure or to a mast for free standing canopies.



© Darcy Schack JAM Photographics Ltd

Stainless Steel Systems

Stainless steel is used for applications where a maintenance-free life is important or where a high quality polished finish is required. This can be particularly impressive when used in conjunction with large areas of glazing.

Cross-Bracing

The use of anchor discs in cross-braced panels will allow bars to lie in the same plane. This removes the need to offset bars, with the disc providing an interesting design feature for the panel.

Glazed Structures

The passage of light is normally a vital consideration in the design of glazed structures. The small profile of the Ancon Tension System ensures the maximum transmission of light while enhancing the overall appearance of the structure.



Tension and Compression Systems

PERFORMANCE AND DIMENSIONS

The design resistances include a material factor (γ_m) of 1.25 against failure. An appropriate partial safety factor (γ_f) will need to be applied to the characteristic dead, imposed and wind loads.

Forks must be correctly aligned, and positioned in the same plane to ensure that bending is not introduced into the tension system.

Design Example

Characteristic dead load = 30.0kN $\gamma_f = 1.35$

Characteristic imposed load = 22.6kN $\gamma_f = 1.5$

Design load = $(30.0 \times 1.35) + (22.6 \times 1.5) = 74.4\text{kN}$

Use Ancon 500/20

Design Resistance = 79.1kN > 74.4kN

Ancon Tension Systems are not suitable for dynamic loads.

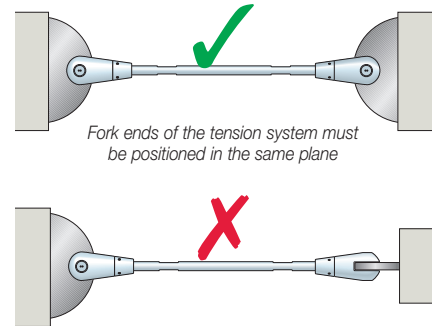

Ancon 500 & 360 Carbon Steel Tension System

Thread Size	500 System									360 System	
	8	10	12	16	20	24	30	36	42	48	56
Design Resistances (kN)	14.0	23.0	34.7	58.7	79.1	133.8	191.6	263.8	351.5	503.2	712.5

Ancon 500 Stainless Steel Tension System

Thread Size	8	10	12	16	20	24	30	36	42
	Design Resistances (kN)	17.1	27.1	37.5	61.2	94.2	165.2	254.6	347.9

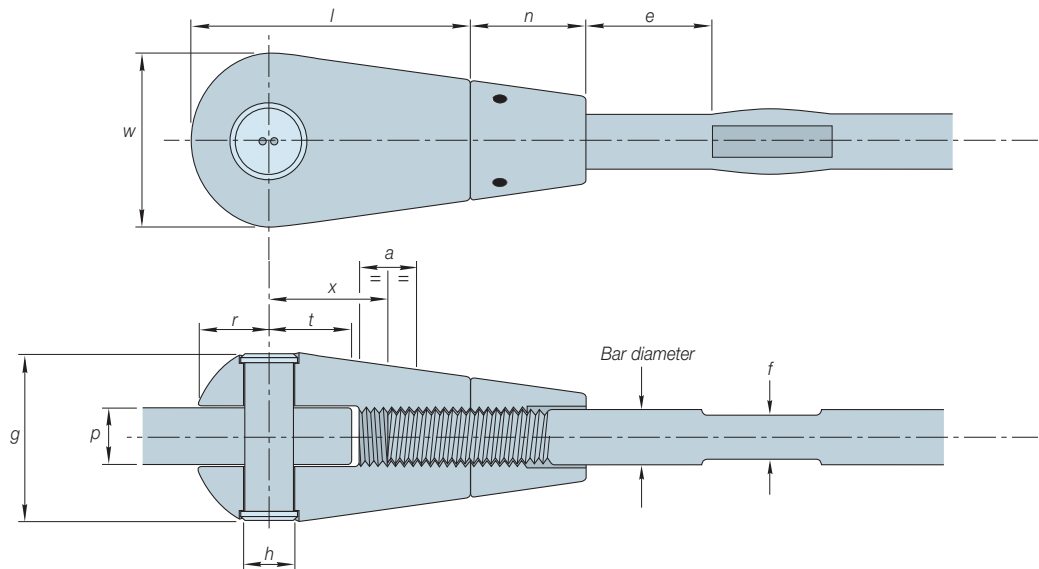

Dimensions of Fork Connectors (mm)

Thread Size		500 System									360 System	
		8	10	12	16	20	24	30	36	42	48	56
Bar Diameter		8	10	12	16	20	24/25	30	35	42/40	45	55
Fork Length	<i>l</i>	40	49	60	78	94	115	140	169	196	224	261
Fork Diameter	<i>w</i>	23.5	29	35	48	60	70	89	106	123	140	164
Plate Thickness	<i>p</i>	8	10	12	16	20	22	30	30	35	40	50
Pin to End	<i>r</i>	10.5	13.5	16	22	28	33	41	50	58	66	77
Pin to Plate Edge	<i>t</i>	12	15	18	23	29	36	43	54	63	74	83
Hole Diameter for Pin	<i>h</i>	7.5	9.5	11.5	14.5	18.5	21.5	26.5	30.5	35.5	42.5	50.5
Pin Length	<i>g</i>	23	28.5	34	46	58	68	86	103	118	135	156
Adjustment	<i>a</i>	9	10	13	15	16	22	25	28	30	35	45
Thickness of Flat	<i>f</i>	6	8	10	14	18	21	27	32	36	41	50
Position of Flat	<i>e</i>	17	20	25	38	43	58	69	84	99	116	139
Pin to Bar End	<i>x</i>	19	23	27	35.5	42	52	62.5	76	89	102.5	116.5
Length of Locking Nut	<i>n</i>	18	22	27	33	38	49	60	71	84	93	108

Notes: The bar diameter of Ancon 500/24 is 24mm in Stainless Steel and 25mm in Carbon Steel. The bar diameter of Ancon 500/42 is 42mm in Stainless Steel and 40mm in Carbon Steel. Ancon 360 Systems are only available in Carbon Steel.

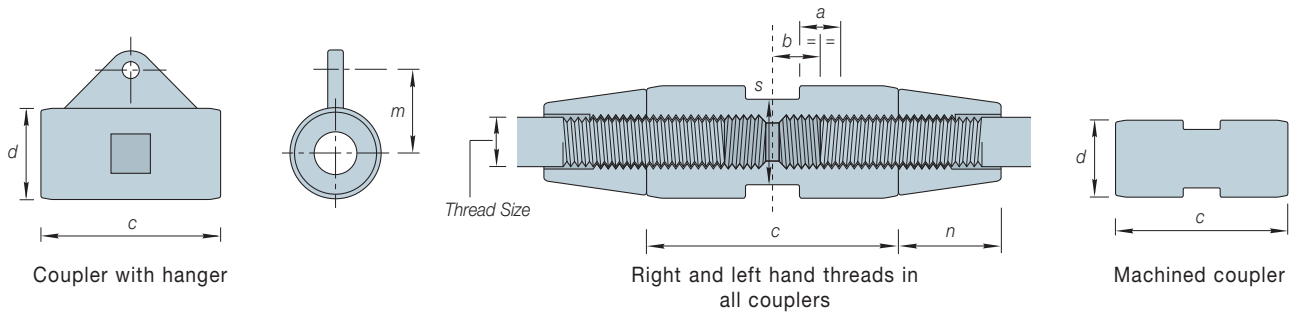

Dimensions of Couplers (mm)

Thread Size	500 System									360 System		
	8	10	12	16	20	24	30	36	42	48	56	
Connector Length	<i>c</i>	38	45	56	83	82	104	125	144.5	166.5	189	226
Connector Diameter	<i>d</i>	17	21	25	35	43	52	65	78	90	103	121
Adjustment	<i>a</i>	9	10	13	15	16	22	25	28	30	35	45
Bar Length Correction	<i>b</i>	8	9.5	11.5	21	17	22	26	29	34	39	45.5
Length of Locking Nut	<i>n</i>	18	22	27	33	38	49	60	71	84	93	108
Hanger Bar Diameter		-	-	-	8	8	8	10	10	10	12	12
Hole Position	<i>m</i>	-	-	-	33.0	37.0	49.0	59.1	74.5	93.1	103.2	123.4
Spanner Size (mm A/F)	<i>s</i>	13	17	19	30	36	46	55	65	75	85	95

Note: Ancon 360 Systems are only available in Carbon Steel.



Maximum Bar Lengths (metres)

Thread Size	500 System									360 System	
	8	10	12	16	20	24	30	36	42	48	56
Untreated	7	7	7	7.5	7.5	7.5	7.5	7.5	7.5	7.5	7.5
Zinc Plated	6	6	6	6	6	6	6	6	6	6	6
Hot-Dip Galvanised	6	6	6	6	6	6	6	6	6	6	6
Stainless Steel	3	3	6	6	6	6	6	6	6	-	-

Note: Material in excess of these lengths can be sourced to meet special project requirements. Contact Ancon for more information.

Minimum Material Specification for Carbon Steel Components

Component	Bar		Fork Connector & Locking Nut		Pin
Thread Size	8-42	48-56	8-12	16-56	8-56
UTS (R _m) N/mm ²	650	520	510	400	610
Yield or 0.2% Proof Stress (R _e) N/mm ²	500	360	355	250	350
Elongation %	16	16	20	20	14
Material Reference	080M40*	080M40	1.0570	1.0570	1.1191

*Selected certified material

Minimum Material Specification for Stainless Steel Components

Component	Bar					Fork Connector & Locking Nut		Pin
Thread Size	8	10	12-20	24-30	36-42	8-12	16-42	8-42
UTS (R _m) N/mm ²	620	650	850	700	650	510	400	520
Yield or 0.2% Proof Stress (R _e) N/mm ²	470	500	780	550	500	355	250	225
Elongation %	40	40	20	20	20	25	25	40
Material Reference	1.4401/4	1.4401/4	1.4462	1.4462	1.4462	1.4462	1.4462	1.4401/4

Tension and Compression Systems

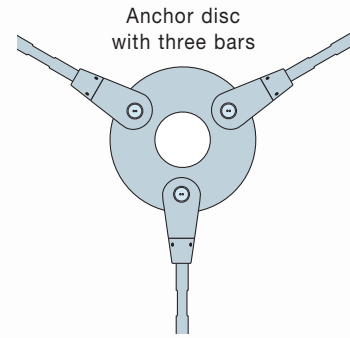
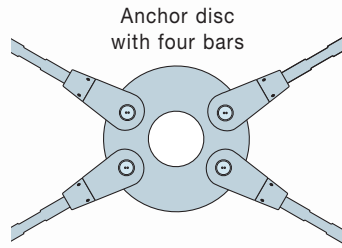

Special Requirements

Ancon can design and manufacture plates in special shapes to replace standard anchor discs and suit the aesthetic requirements of any application.

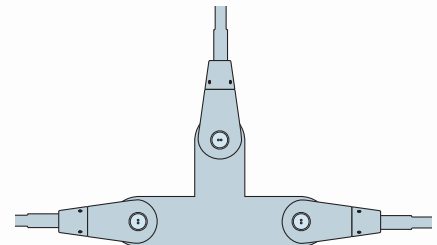

Special anchor plate with three bars

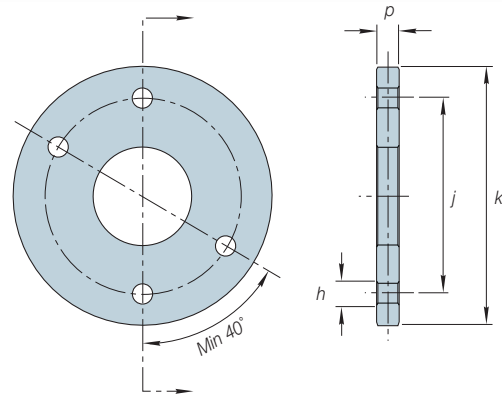

ANCHOR DISCS

Dimensions of Anchor Discs (mm)

Thread Size		500 System									360 System	
		8	10	12	16	20	24	30	36	42	48	56
Disc Thickness	p	8	10	12	16	20	22	30	30	35	40	50
Overall Diameter	k	100	123	148	196	242	282	355	425.5	493.5	563	654
Effective Diameter	j	76	93	112	150	184	212	269	318	367	416	488
Hole Diameter for Pin	h	7.5	9.5	11.5	14.5	18.5	21.5	26.5	30.5	35.5	42.5	50.5

Note: Ancon 360 Systems are only available in Carbon Steel.

CONNECTING PLATES

Connecting plates should be designed to suit each application. The critical dimensions are provided in the table and diagrams. In the examples shown here θ is 45° . These plates should be manufactured from either grade S355 carbon steel or grade 1.4462 stainless steel; users should consider the corrosion properties of the material selected. Isolation material is supplied as standard with the stainless steel tension system to enable its fixing to a connecting plate of a dissimilar metal.

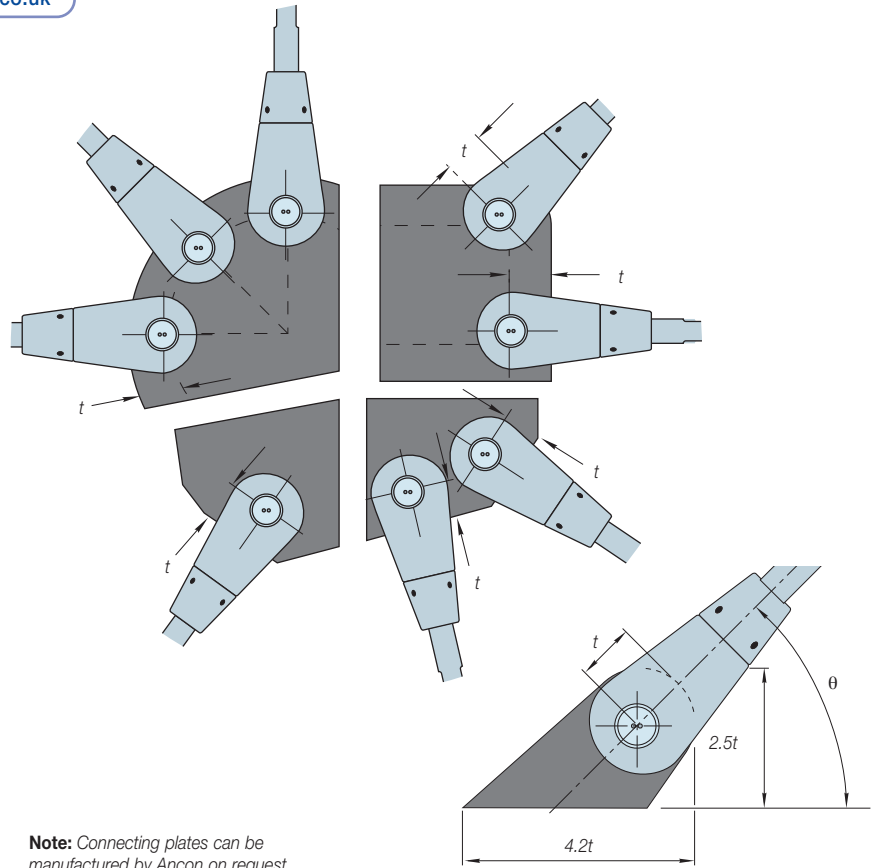
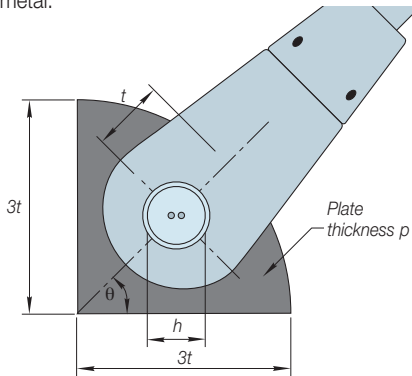

Dimensions of Connecting Plates (mm)

Thread Size	500 System									360 System		
	8	10	12	16	20	24	30	36	42	48	56	
Plate Thickness	<i>p</i>	8	10	12	16	20	22	30	30	35	40	50
Hole Diameter	<i>h</i>	7.5	9.5	11.5	14.5	18.5	21.5	26.5	30.5	35.5	42.5	50.5
Position of Hole	<i>t</i>	12	15	18	23	29	36	43	54	63	74	83

Notes: Ancon 360 Systems are only available in Carbon Steel. Required minimum yield stress (0.2% proof stress for stainless) for material for connecting plates is 350N/mm². Required minimum UTS for material for connecting plates is 460N/mm².

SPECIFYING AND ORDERING

Ancon Tension Systems are supplied as full systems and are not available as individual components.

System lengths are measured between the centres of the pins in the forks. The bar lengths are shown in the table on page 11 and should be considered when determining the system length.

Electrodeposited zinc coating Fe//Zn12//A to EN 12329 on bars and discs will provide some protection against corrosion, but is only intended to be used for systems which are internal installations. Hot-dip galvanising to EN 1461 will provide greater protection but should be considered as only part of the overall protection treatment. Stainless steel affords the greatest protection and does not require any further treatment.

The Ancon Tension System can be specified as follows: *System / size / system length / material / finish*.

A fully polished Ancon 500 stainless steel system using 16mm diameter bar, 2750mm between the pins would be specified as:- *Ancon 500/16/2750/SS/6*. The material and finish codes are from the adjacent table.

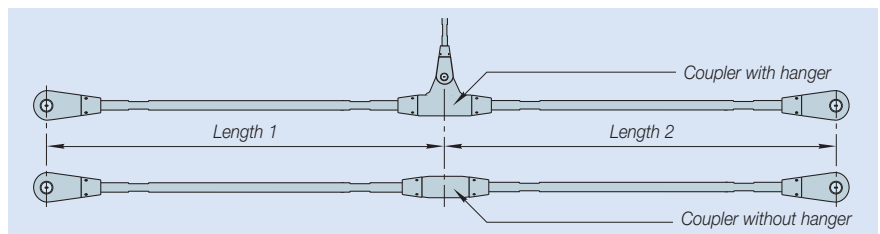
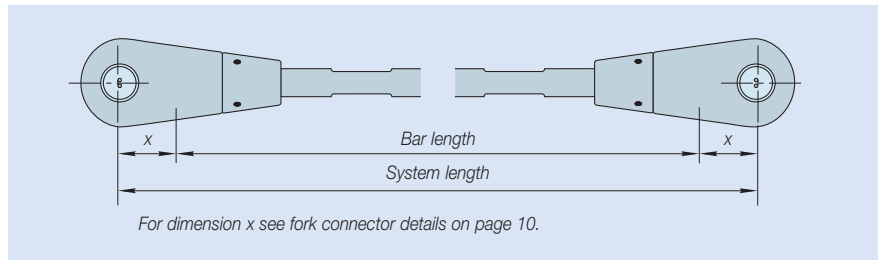

Material and Finish Codes

Code	Material	Bar	Surface Finish		
			Fork & Nut	Coupler	Disc
CS/1	Carbon	Untreated	Zinc plated	Zinc plated	Untreated
CS/2	Carbon	Zinc plated	Zinc plated	Zinc plated	Zinc plated
CS/3	Carbon	Hot-dip galvanised	Zinc plated	Zinc plated	Hot-dip galvanised
SS/4	Stainless	Bright drawn	Electro-polished	Machined	Machined
SS/5	Stainless	Bright drawn	Satin-polished	Satin-polished	Satin-polished
SS/6	Stainless	Hand polished	Hand polished	Hand polished	Hand polished

Notes: This table includes Ancon's standard finishes. Other finishes are available on request.

Tension and Compression Systems

INSTALLATION GUIDANCE

It is important to follow Ancon's installation instructions, supplied with each system, to ensure that the Tension System meets the performance criteria.

The locking nuts should be fully screwed onto the bar at each end and the bar screwed into the forks using an open ended spanner of the correct size. When the required system length is reached, the locking nuts must be turned back to the fork and tightened using soft touch pliers for Ancon 500/8 to 12 or a hook spanner for Ancon 500/16 and above and the Ancon 360 System.

When the installation is complete, all threads should be hidden within the locking nut. If the thread is visible, the bar is not sufficiently engaged in the fork and would need to be adjusted.

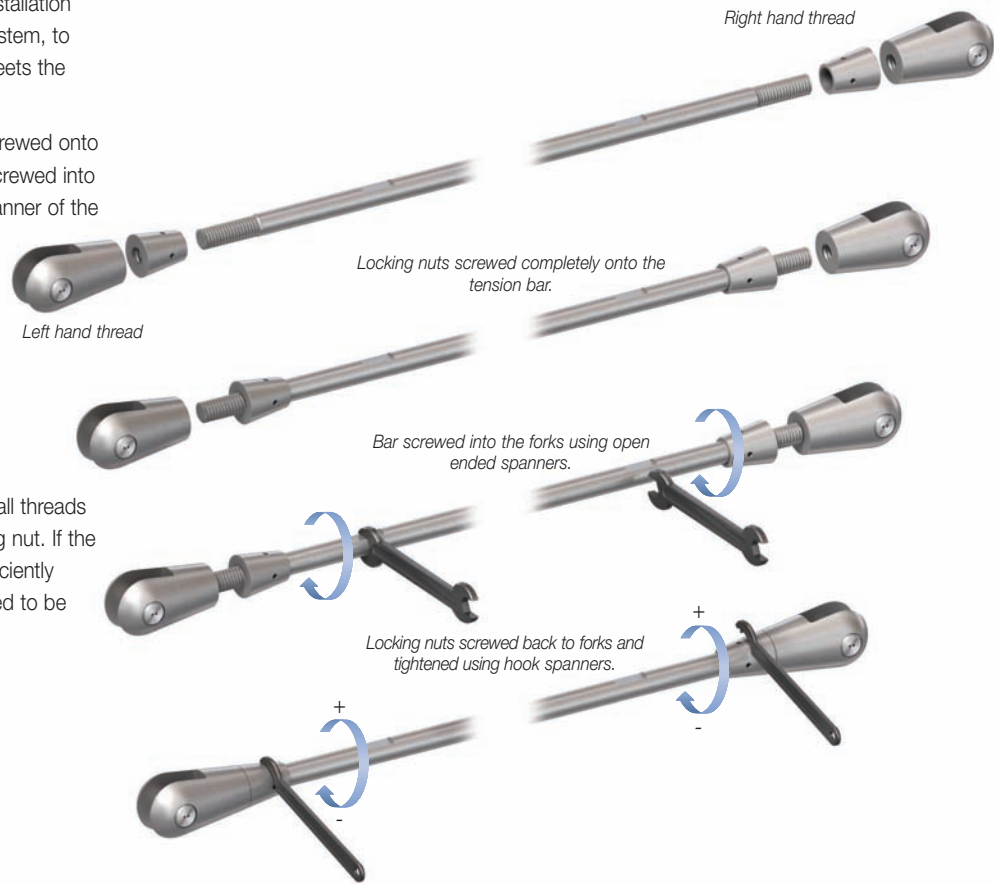

Each fork is supplied with a locking nut and pin to enable fixing to a connecting plate or anchor disc.

The installation requires a twin-pin driver. Two driver bits of the appropriate size are supplied with each Ancon system. This type of fixing, known as 'Snake Eyes*', allows a high torque to be achieved without damage to the pin.

The female section of the pin is located through the fork connector and temporarily held in position. A second driver is then used to wind the male section into position creating a secure connection.

Each stainless steel fork connector is supplied with two clear, self-adhesive, PET (polyester) washers to isolate the system from a connecting plate of a dissimilar metal. These washers should be applied around the fixing hole, either side of the plate, prior to the installation of the fork connector.

Incorrect installation



Correct installation with no thread visible

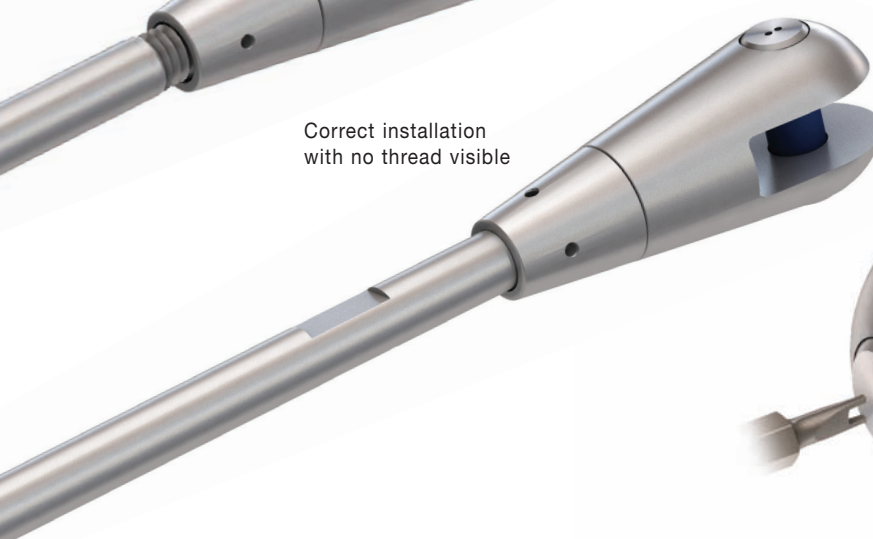

Forks must be correctly aligned, and positioned in the same plane to ensure that bending is not introduced into the tension system.

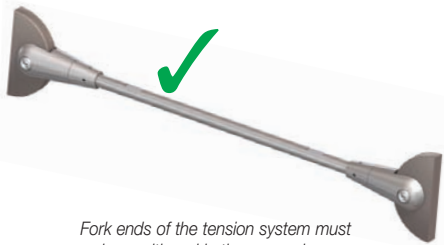

The maximum misalignment of an Ancon System is 0.5° as illustrated below.

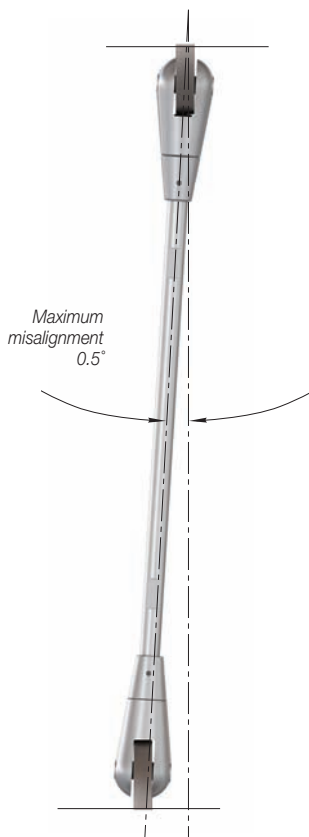

For further information or advice on specific applications please contact Ancon's Technical Services Team.

OTHER ANCON PRODUCTS

Wall Ties and Restraint Fixings

Ancon's standard range includes cavity wall ties for all types of construction including traditional brick/block, thin-joint blockwork and timber or steel frames. Many fixings can be supplied within twenty-four hours of receiving an order. Bespoke wall ties can be ordered by using a simple reference system for the head, shank and tail of the tie.

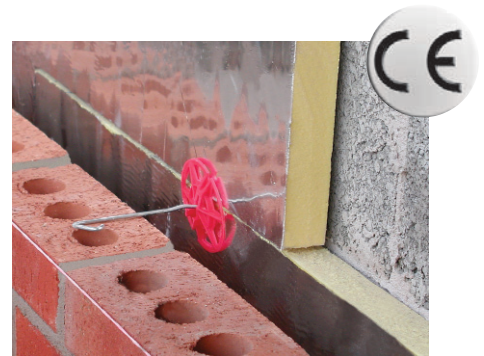

Masonry Support Systems

Masonry cladding on steel or concrete framed structures is normally supported from a stainless steel support system, positioned above the horizontal movement joints. Ancon designs solutions for all conditions including the support of special masonry features. The range includes the standard AnconOptima system consisting of short lengths of angle and interchangeable brackets of various depths to accommodate variations in cavity width on site.



Masonry Reinforcement

Ancon AMR Masonry Reinforcement and Ancon Windposts are designed to provide additional lateral support for panels of brickwork. Windposts can be installed into either the inner leaf of blockwork or into the cavity, leaving the blockwork undisturbed. Ancon AMR is a fabricated and flattened stainless steel and carbon steel reinforcement, which locates in the bed joint to strengthen a wall. Parapet Posts are used as vertical support for brickwork in either parapet or spandrel panels.



Insulated Balcony Connectors

Ancon Isolan connectors join external concrete balconies to internal concrete floor slabs. Used to minimise cold bridging, they provide continuity to the thermal insulation. Standard systems, comprising rigid CFC-free polystyrene insulation and duplex stainless steel shear reinforcement, suit most depths of cantilevered and simply supported balconies. Unique to the Isolan system, conventional reinforcing bars are used to provide the tension and compression reinforcement.



Shear Load Connectors

Ancon DSD and ESD Shear Load Connectors are used to transfer shear across expansion and contraction joints in concrete. They are more effective at transferring load and allowing movement to take place than simple single dowels, and can be used to eliminate double columns at structural movement joints in concrete frames.



Ancon Building Products

President Way, President Park
Sheffield S4 7UR
United Kingdom
Tel: +44 (0) 114 275 5224
Fax: +44 (0) 114 276 8543
Email: info@ancon.co.uk
Visit: www.ancon.co.uk

Ancon (Middle East) FZE

PO Box 17225
Jebel Ali
Dubai
United Arab Emirates
Tel: +971 (0) 4 883 4346
Fax: +971 (0) 4 883 4347
Email: info@ancon.ae
Visit: www.ancon.ae

Ancon Building Products

114 Kurrajong Avenue
Mount Druitt
Sydney
NSW 2770
Australia
Tel: +61 (0) 2 8808 1111
Fax: +61 (0) 2 9675 3390
Email: info@ancon.com.au
Visit: www.ancon.com.au

Ancon (Schweiz) AG

Gewerbezone Widalmi 10
3216 Ried bei Kerzers
Switzerland
Tel: +41 (0) 31 750 3030
Fax: +41 (0) 31 750 3033
Email: info@ancon.ch
Visit: www.ancon.ch

Ancon Building Products GesmbH

Puchgasse 1
A-1220 Vienna
Austria
Tel: +43 (0) 1 259 58 62-0
Fax: +43 (0) 1 259 58 62-40
Email: info@ancon.at
Visit: www.ancon.at

Ancon GmbH

Bartholomäusstrasse 26
90489 Nuremberg
Germany
Tel: +49 (0) 911 955 1234 0
Fax: +49 (0) 911 955 1234 9
Email: info@anconbp.de
Visit: www.anconbp.de

These products are available from:

© Ancon Building Products 2013

The construction applications and details provided in this literature are indicative only. In every case, project working details should be entrusted to appropriately qualified and experienced persons.

Whilst every care has been exercised in the preparation of this document to ensure that any advice, recommendations or information is accurate, no liability or responsibility of any kind is accepted in respect of Ancon Building Products.

With a policy of continuous product development Ancon Building Products reserves the right to modify product design and specification without due notice.



ISO 9001: 2008
FM 12226



ISO 14001: 2004
EMS 505377



OHSAS 18001: 2007
OHS 548992